

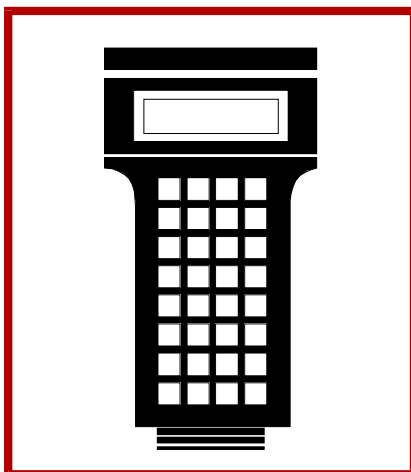

Instruction

Multi-Function Processor Module (IMMFP01)

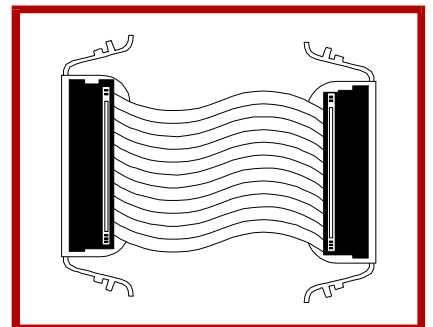
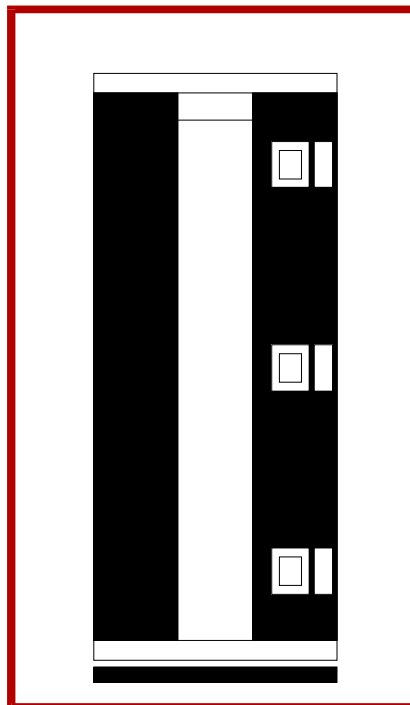
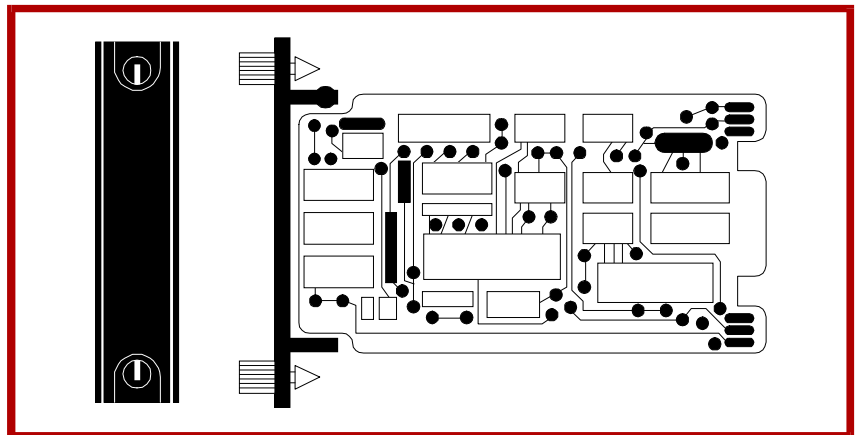

WARNING notices as used in this instruction apply to hazards or unsafe practices that could result in personal injury or death.

CAUTION notices apply to hazards or unsafe practices that could result in property damage.

NOTES highlight procedures and contain information that assists the operator in understanding the information contained in this instruction.

WARNING

INSTRUCTION MANUALS

DO NOT INSTALL, MAINTAIN, OR OPERATE THIS EQUIPMENT WITHOUT READING, UNDERSTANDING, AND FOLLOWING THE PROPER **Elsag Bailey** INSTRUCTIONS AND MANUALS; OTHERWISE, INJURY OR DAMAGE MAY RESULT.

RADIO FREQUENCY INTERFERENCE

MOST ELECTRONIC EQUIPMENT IS INFLUENCED BY RADIO FREQUENCY INTERFERENCE (RFI). CAUTION SHOULD BE EXERCISED WITH REGARD TO THE USE OF PORTABLE COMMUNICATIONS EQUIPMENT IN THE AREA AROUND SUCH EQUIPMENT. PRUDENT PRACTICE DICTATES THAT SIGNS SHOULD BE POSTED IN THE VICINITY OF THE EQUIPMENT CAUTIONING AGAINST THE USE OF PORTABLE COMMUNICATIONS EQUIPMENT.

POSSIBLE PROCESS UPSETS

MAINTENANCE MUST BE PERFORMED ONLY BY QUALIFIED PERSONNEL AND ONLY AFTER SECURING EQUIPMENT CONTROLLED BY THIS PRODUCT. ADJUSTING OR REMOVING THIS PRODUCT WHILE IT IS IN THE SYSTEM MAY UPSET THE PROCESS BEING CONTROLLED. SOME PROCESS UPSETS MAY CAUSE INJURY OR DAMAGE.

AVERTISSEMENT

MANUELS D'OPÉRATION

NE PAS METTRE EN PLACE, RÉPARER OU FAIRE FONCTIONNER L'ÉQUIPEMENT SANS AVOIR LU, COMPRIS ET SUIVI LES INSTRUCTIONS RÉGLEMENTAIRES DE **Elsag Bailey**. TOUTE NÉGLIGENCE À CET ÉGARD POURRAIT ÊTRE UNE CAUSE D'ACCIDENT OU DE DÉFAILLANCE DU MATÉRIEL.

PERTURBATIONS PAR FRÉQUENCE RADIO

LA PLUPART DES ÉQUIPEMENTS ÉLECTRONIQUES SONT SENSIBLES AUX PERTURBATIONS PAR FRÉQUENCE RADIO. DES PRÉCAUTIONS DEVRONT ÊTRE PRISES LORS DE L'UTILISATION DU MATÉRIEL DE COMMUNICATION PORTATIF. LA PRUDENCE EXIGE QUE LES PRÉCAUTIONS À PRENDRE DANS CE CAS SOIENT SIGNALÉES AUX ENDROITS VOULUS DANS VOTRE USINE.

PERTURBATIONS DU PROCÉDÉ

L'ENTRETIEN DOIT ÊTRE ASSURÉ PAR UNE PERSONNE QUALIFIÉE EN CONSIDÉRANT L'ASPECT SÉCURITAIRE DES ÉQUIPEMENTS CONTRÔLÉS PAR CE PRODUIT. L'AJUSTEMENT ET/OU L'EXTRACTION DE CE PRODUIT PEUT OCCASIONNER DES À-COUPS AU PROCÉDÉ CONTRÔLE LORSQU'IL EST INSÉRÉ DANS UNE SYSTÈME ACTIF. CES À-COUPS PEUVENT ÉGALEMENT OCCASIONNER DES BLESSURES OU DES DOMMAGES MATÉRIELS.

NOTICE

The information contained in this document is subject to change without notice.

Elsag Bailey, its affiliates, employees, and agents, and the authors and contributors to this publication specifically disclaim all liabilities and warranties, express and implied (including warranties of merchantability and fitness for a particular purpose), for the accuracy, currency, completeness, and/or reliability of the information contained herein and/or for the fitness for any particular use and/or for the performance of any material and/or equipment selected in whole or part with the user of/or in reliance upon information contained herein. Selection of materials and/or equipment is at the sole risk of the user of this publication.

This document contains proprietary information of Elsag Bailey, Elsag Bailey Process Automation, and is issued in strict confidence. Its use, or reproduction for use, for the reverse engineering, development or manufacture of hardware or software described herein is prohibited. No part of this document may be photocopied or reproduced without the prior written consent of Elsag Bailey.

Preface

The IMMFP01 Multi-Function Processor Module is a powerful stand-alone controller for use in complex control applications. It has the processing speeds and storage capabilities necessary for advanced control applications. The IMMFP01 module is a user-configurable device that receives process input and output through a variety of analog and digital I/O modules.

This instruction manual provides information about how the IMMFP01 module works and how to install, configure, operate, and troubleshoot the module.

List of Effective Pages

Total number of pages in this instruction is 72, consisting of the following:

Page No.	Change Date
Preface	Original
List of Effective Pages	Original
iii through viii	Original
1-1 through 1-6	Original
2-1 through 2-4	Original
3-1 through 3-10	Original
4-1 through 4-4	Original
5-1 through 5-12	Original
6-1 through 6-4	Original
7-1	Original
8-1	Original
A-1 through A-4	Original
B-1 through B-6	Original
C-1 through C-5	Original
D-1 through D-5	Original
Index-1 through Index-2	Original

When an update is received, insert the latest changed pages and dispose of the superseded pages.

NOTE: On an update page, the changed text or table is indicated by a vertical bar in the outer margin of the page adjacent to the changed area. A changed figure is indicated by a vertical bar in the outer margin next to the figure caption. The date the update was prepared will appear beside the page number.

Safety Summary

GENERAL WARNINGS

Equipment Environment

All components, whether in transportation, operation or storage, must be in a noncorrosive environment.

Electrical Shock Hazard During Maintenance

Disconnect power or take precautions to insure that contact with energized parts is avoided when servicing.

Special Handling

This module uses electrostatic sensitive devices.

SPECIFIC WARNINGS

Disconnect power before installing dipshunts on the module mounting unit backplane. Failure to do so will result in contact with cabinet areas that could cause severe or fatal shock. (p. 3-7)

Wear eye protection whenever working with cleaning solvents. When removing solvents from printed circuit boards using compressed air, injury to the eyes could result from splashing solvent as it is blown off the printed circuit board. (p. 6-1)

SPECIFIC CAUTIONS

Never operate the MFP module with the machine fault timer circuit disabled (jumper pins connected). Unpredictable module outputs and configuration corruption may result. The unpredictable module outputs may damage control equipment connected to the MFP module. (p. 3-9)

To avoid potential module damage, evaluate your system for compatibility prior to module installation. This module uses connections to the module mounting unit backplane that served other functions in early Network 90 systems. (p. 3-10)

Sommaire de Sécurité

**AVERTISSEMENT
D'ORDRE
GENERAL****Environnement de l'Équipement**

Nes pas soumettre les composantes a une atmosphere corrosive lors du transport, de l'entreposage ou de l'utilisation.

Risques de Chocs Electriques lor de l'Entretien

S'assurer de debrancher l'alimentation ou de prende les precautions necessaires a eviter tout contact avec des composants sous tension lors de l'entretien.

Precautions de Manutention

Ce module contient des composantes sensibles aux decharges electro-statiques.

**AVERTISSEMENT
D'ORDRE
SPECIFIQUE**

Interrompez l'alimentation avante d'installer des dipshunts sur le fond de panier du châssis de montage des modules. Sinon, tout contact avec cette zone entraîne des risques d'électrocution sérieuse ou fatale. (p. 3-7)

Portez toujours des lunettes de protection lorsque vous utilisez des solvants de nettoyage. L'air comprimé servant à enlever le solvant des cartes de circuits imprimés provoque des éclaboussures qui risquent d'atteindre les yeux. (p. 6-1)

**ATTENTION
D'ORDRE
SPECIFIQUE**

N'utilisez jamais un module MFP sans l'usage de sa minuterie de détection de défaillance (c'est à dire avec le cavalier en place). Les sorties du module pourraient prendre des valeurs ou des états imprévisibles, et la configuration pourrait être corrompue. Le comportement imprévisible des sorties pourrait endommager le matériel de commande relié au module MFP. (p. 3-9)

Pour éviter d'endommager des modules, évaluez la compatibilité de votre système avante de les y brancher. L'usage que fait ce module de certaines connexions au fond de panier du châssis de montage diffère de l'assignation prévue par le système Network 90 original. (p. 3-10)

Table of Contents

	<i>Page</i>
SECTION 1 - INTRODUCTION	1-1
OVERVIEW	1-1
INTENDED USER	1-1
HARDWARE DESCRIPTION	1-1
Faceplate	1-2
Circuit Board	1-3
HARDWARE APPLICATION	1-3
FEATURES	1-3
INSTRUCTION CONTENT	1-3
HOW TO USE THIS MANUAL	1-4
REFERENCE DOCUMENTS	1-4
NOMENCLATURE	1-5
GLOSSARY OF TERMS AND ABBREVIATIONS	1-5
SPECIFICATIONS	1-6
SECTION 2 - DESCRIPTION AND OPERATION	2-1
INTRODUCTION	2-1
MICROPROCESSOR	2-1
CLOCK AND TIMER	2-2
MEMORY	2-2
I/O EXPANDER BUS	2-2
I/O SECTION	2-2
SERIAL CHANNELS	2-3
DMA SECTION	2-3
CONTROLWAY	2-3
REDUNDANCY LINK	2-4
STATION LINK	2-4
SECTION 3 - INSTALLATION	3-1
INTRODUCTION	3-1
SPECIAL HANDLING	3-1
UNPACKING AND INSPECTION	3-2
SETUP AND PHYSICAL INSTALLATION	3-2
Dipswitch SW3 Settings	3-3
Dipswitch SW4 Settings	3-3
Special Operations	3-5
Jumpers J1 through J5	3-6
PREPARING THE MODULE MOUNTING UNIT	3-7
Dipshunts	3-7
Controlway Cable	3-8
INSTALLING THE TERMINATION UNIT OR MODULE	3-8
NTMP01 Termination Unit Installation	3-8
NIMP01 or NIMP02 Termination Module Installation	3-9
INSTALLING THE MODULE	3-9
SECTION 4 - OPERATING PROCEDURES	4-1
INTRODUCTION	4-1
START-UP	4-1
LED INDICATORS	4-1
Front Panel LEDs One through Eight	4-2
Red/Green Status LED	4-2
STOP/RESET SWITCH	4-3

Table of Contents (continued)

	<i>Page</i>
<hr/>	
SECTION 4 - OPERATING PROCEDURES (continued)	
MODES OF OPERATION	4-4
Configure Mode	4-4
Execute Mode	4-4
Error Mode	4-4
<hr/>	
SECTION 5 - TROUBLESHOOTING.....	5-1
INTRODUCTION	5-1
CARD EDGE CONNECTORS	5-5
DIAGNOSTICS	5-6
Overview	5-6
Dipswitch Selection	5-7
LED Display	5-9
MODULE STATUS SUMMARY	5-10
<hr/>	
SECTION 6 - MAINTENANCE.....	6-1
INTRODUCTION	6-1
PREVENTIVE MAINTENANCE SCHEDULE	6-1
EQUIPMENT AND TOOLS REQUIRED	6-2
PREVENTIVE MAINTENANCE PROCEDURES	6-2
Printed Circuit Board Cleaning	6-2
General Cleaning and Washing	6-3
Edge Connector Cleaning	6-3
Checking Connections	6-3
<hr/>	
SECTION 7 - REPAIR/REPLACEMENT PROCEDURES	7-1
INTRODUCTION	7-1
MODULE REPLACEMENT PROCEDURE	7-1
TERMINATION UNIT OR MODULE REPLACEMENT PROCEDURES	7-1
<hr/>	
SECTION 8 - SUPPORT SERVICES.....	8-1
INTRODUCTION	8-1
REPLACEMENT PARTS AND ORDERING INFORMATION	8-1
TRAINING.....	8-1
TECHNICAL DOCUMENTATION.....	8-1
<hr/>	
APPENDIX A - QUICK REFERENCE MATERIAL	A-1
INTRODUCTION	A-1
<hr/>	
APPENDIX B - ON-LINE CONFIGURATION	B-1
INTRODUCTION	B-1
SETUP.....	B-1
OPERATION.....	B-1
Backup Cycle	B-3
Primary Cycle	B-4
<hr/>	
APPENDIX C - NTMP01 TERMINATION UNIT CONFIGURATION	C-1
INTRODUCTION	C-1
<hr/>	
APPENDIX D - NIMP01 AND NIMP02 TERMINATION MODULE CONFIGURATION.....	D-1
INTRODUCTION	D-1

List of Figures

<i>No.</i>	<i>Title</i>	<i>Page</i>
1-1.	Example IMMFP01 Module Applications	1-2
2-1.	IMMFP01 Module Functional Block Diagram	2-1
3-1.	IMMFP01 Module Layout	3-3
3-2.	Controlway Cable Installation	3-8
4-1.	IMMFP01 Front Panel LEDs and Controls	4-2
5-1.	IMMFP01 Troubleshooting Flowchart (Serial Port)	5-4
5-2.	IMMFP01 Troubleshooting Flowchart (Status LED)	5-5
5-3.	Diagnostic Dipswitch Settings	5-8
5-4.	LEDs - Pass/Fail.....	5-10
B-1.	Backup MFP Module Operating Cycle.....	B-5
B-2.	Primary MFP Module Operating Cycle	B-6
C-1.	DTE Jumper Configuration for NTMP01 Termination Unit	C-1
C-2.	DCE Jumper Configuration for NTMP01 Termination Unit	C-2
C-3.	NTMP01 Nonhandshake Jumper Configuration	C-2
C-4.	NTMP01 Loopback Jumper Configuration	C-3
C-5.	NTMP01 Jumpers J3 through J10 Configuration	C-3
C-6.	NTMP01 Jumpers J14 through J17 Configuration	C-4
C-7.	NTMP01 Connector Assignments and Jumper Locations	C-4
C-8.	NTMP01 Cable Connections for Redundant MFP Modules	C-5
C-9.	NTMP01 Cable Connections for a Single MFP Module	C-5
D-1.	DTE Jumper Configuration for NIMP01 Termination Module	D-2
D-2.	DCE Jumper Configuration for NIMP01 Termination Module	D-2
D-3.	NIMP01 Nonhandshake Jumper Configuration.....	D-3
D-4.	NIMP01 Loopback Jumper Configuration	D-3
D-5.	NIMP01 Jumpers J5 through J10 Configuration	D-3
D-6.	NIMP01 Jumpers J14 through J17 Configuration	D-4
D-7.	NIMP01 Connector Assignments and Jumper Locations	D-4
D-8.	NIMP01 and NIMP02 Cable Connections for Redundant MFP Modules	D-5
D-9.	NIMP01 Cable Connections for a Single MFP Module	D-5

List of Tables

<i>No.</i>	<i>Title</i>	<i>Page</i>
1-1.	Reference Documents	1-4
1-2.	Nomenclature	1-5
1-3.	Glossary of Terms and Abbreviations	1-5
1-4.	Specifications.....	1-6
3-1.	IMMFP01 Dipswitch SW3 Settings	3-4
3-2.	Example IMMFP01 Module Address Settings	3-4
3-3.	IMMFP01 Dipswitch SW4 Normal Operation Settings	3-4
3-4.	IMMFP01 Dipswitch SW4 Special Operation Settings	3-5
3-5.	IMMFP01 Jumper J1 through J5 Settings	3-7
5-1.	IMMFP01 Module Error Codes	5-1
5-2.	IMMFP01 Module Error Codes	5-3
5-3.	IMMFP01 Connector P1 Pin Assignments	5-5
5-4.	IMMFP01 Connector P2 Pin Assignments	5-6
5-5.	IMMFP01 Connector P3 Pin Assignments	5-6
5-6.	IMDSM05 Module Setup for IMMFP01 Tests	5-7

List of Figures (continued)

<i>No.</i>	<i>Title</i>	<i>Page</i>
5-7.	IMDSM05 Jumper Settings for IMMFP02 Tests	5-7
5-8.	Diagnostic Tests	5-8
5-9.	IMMFP01 Module Status Report	5-11
5-10.	Field Descriptions of the IMMFP01 Module Status Report	5-11
6-1.	Preventive Maintenance Schedule	6-2
8-1.	Spare Parts List	8-1
A-1.	IMMFP01 Dipswitch SW3 Settings	A-1
A-2.	IMMFP01 Dipswitch SW4 Settings	A-1
A-3.	IMMFP01 Jumper J5 Settings.....	A-2
A-4.	IMMFP01 Module Error Codes	A-2
A-5.	Other IMMFP01 Module LED Conditions	A-4
B-1.	Legend of Symbols.....	B-2
B-2.	Backup Cycle	B-3
B-3.	Primary Cycle	B-5

SECTION 1 - INTRODUCTION

OVERVIEW

The IMMFP01 Multi-Function Processor Module (MFP) is one of the workhorses of the INFI 90[®] control module line. It is a multiple loop analog, sequential, batch and advanced controller that provides powerful solutions to process control problems. It also handles data acquisition and information processing requirements providing true peer-to-peer communications. The comprehensive set of function codes supported by this module handles even the most complex control strategies. The INFI 90 system uses a variety of analog and digital I/O modules to communicate with and control the process. The MFP module communicates with a maximum of 64 I/O modules in any combination (see Figure 1-1).

The MFP module has three operating modes: execute, configure and error. In the execute mode, the MFP module executes control algorithms while constantly checking itself for errors. When an error is found, the front panel LEDs display an error code corresponding to the type of error found. In the configure mode, it is possible to edit existing or add new control algorithms. In this mode, the MFP module does not execute control algorithms. If the MFP module finds an error while in execute mode, it automatically goes into error mode. Refer to [Section 4](#) of this manual for operating mode details.

A one-megabaud CPU to CPU communication link allows the MFP module to accommodate redundant processors. This link enables a backup MFP module to wait in a hot standby mode while the primary MFP module executes the control algorithms. If the primary MFP module goes off-line for any reason, a bumpless transfer of control to the backup MFP module occurs.

INTENDED USER

Personnel installing, operating, or maintaining the MFP module should read this manual before performing any installation, operation, or maintenance procedures. Installation requires an engineer or technician with experience handling electronic circuitry. Formal training in INFI 90 systems and configuration (especially function codes) would help when configuring the MFP module.

HARDWARE DESCRIPTION

The multi-function processor module consists of a faceplate and circuit board.

[®] INFI 90 is a registered trademark of Elsasg Bailey Process Automation.

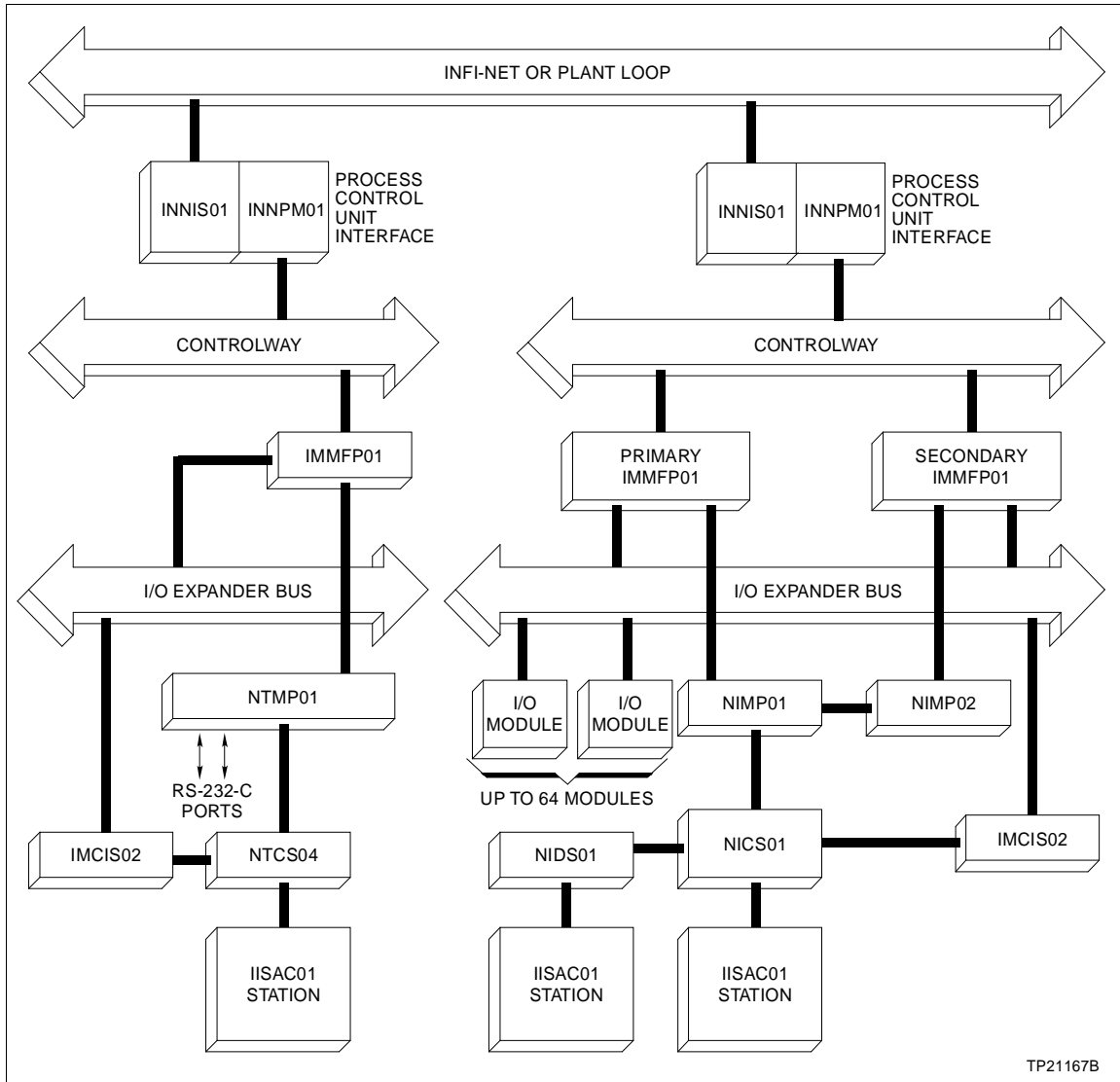

Figure 1-1. Example IMMFP01 Module Applications

Faceplate

The MFP faceplate measures 35.56 millimeters wide by 177.80 millimeters high (1.4 inches wide by seven inches high). Two latching screws, one at the top, the other at the bottom, lock the module assembly into the module mounting unit. A transparent window on the faceplate permits viewing of LEDs one through eight and the status LED. These LEDs display operating information. A small hole directly below the window provides access to the combination stop/reset pushbutton. Besides locking the module in place, the faceplate also protects the circuit components and promotes proper air flow within the cabinet.

Circuit Board

The circuit board features state-of-the-art circuitry. On-board circuitry consists of nonvolatile random access memory (NVRAM), random access memory (RAM), read only memory (ROM), a microprocessor running at 16 megahertz, direct memory access (DMA) circuits, Bailey custom bus circuits and various support circuitry. The board attaches to the faceplate with two screws. The module assembly occupies one slot in a module mounting unit.

HARDWARE APPLICATION

The multi-function processor module is ideally suited for applications requiring multiple loop control and module I/O. Since it handles both analog and digital signals, the MFP module fits into virtually any control scheme.

FEATURES

The MFP module has the following features:

- A high speed redundancy link.
- A serial communication port for station support.
- Two general purpose serial channels.
- Direct memory access circuitry.
- 256 kilobytes of RAM memory.
- 64 kilobytes of NVRAM memory.

INSTRUCTION CONTENT

This manual consists of eight sections and four appendices:

Introduction	This section provides an overview of the module, a description of the hardware, a glossary of unique terms, and a table of physical, electrical, and environmental specifications.
Description and Operation	How the key circuits function is explained in this section.
Installation	The handling, inspection, hardware configuration, and installation aspects of the module are described in this section.
Operating Procedures	Front panel indicators and controls, and everyday operations are discussed in this section.
Troubleshooting	This section features detailed flow charts and tables that enable quick diagnosis of error conditions and provide corrective actions.

- Maintenance** Scheduled module maintenance is covered by this section.
- Repair/Replacement Procedures** This section describes how to replace the module.
- Support Services** A list of the replacement parts and an explanation of the warranty policy are contained in this section.
- Appendices** These appendices provide quick reference information for the hardware configuration of the IMMFP01 module and associated termination units and modules and step by step instructions for performing on-line configuration.

HOW TO USE THIS MANUAL

Read this instruction in sequence. Read **Section 3** thoroughly. It is important to become familiar with the entire contents of this instruction before using the MFP module. Refer to the table of contents or index to find specific information after the module is operating.

1. Complete all steps in **Section 3**.
2. Thoroughly read **Section 4** before applying power to the module.
3. Refer to **Section 5** if a problem occurs. This section will help to diagnose and correct a problem.
4. Refer to **Section 6** for scheduled maintenance requirements.
5. Go to **Section 7** to find instructions on how to replace the module.
6. Refer to **Section 8** for replacement part and warranty information.

REFERENCE DOCUMENTS

Table **1-1** lists the documents that provide additional information for related equipment. Refer to them as needed.

Table 1-1. Reference Documents

Number	Document
I-E96-200	Function Code Application Manual
I-E96-401	NIMP01/02 Multi-Function Processor Termination Module
I-E96-428	NTMP01 Multi-Function Processor Termination Unit

NOMENCLATURE

Table 1-2 lists the nomenclature of related hardware.

Table 1-2. Nomenclature

Nomenclature	Hardware/Description
IMMFP01	Multi-function processor module
NIMP01/02	Multi-function processor termination module
NKSE01	Serial extension cable (PVC)
NKSE11	Serial extension cable (non-PVC)
NKTU01	Termination unit cable (PVC)
NKTU02	Termination module cable (PVC)
NKTU11	Termination unit cable (non-PVC)
NKTU12	Termination module cable (non-PVC)
NTMP01	Multi-function processor termination unit

GLOSSARY OF TERMS AND ABBREVIATIONS

Table 1-3 lists the definitions of terms and abbreviations used in this instruction that are unique to Bailey Controls Company.

Table 1-3. Glossary of Terms and Abbreviations

Term	Description
Configuration	The act of setting up equipment to accomplish specific functions or a list of parameters associated with such a setup.
Controlway	High speed, redundant, peer-to-peer communication link. Used to transfer information between intelligent modules within a process control unit.
Dipswitch	A dual in-line package that contains switches.
EWS	Engineering work station.
Executive Block	Fixed function block that determines overall module operating characteristics.
Function Block	The occurrence of a function code at a block address of a module.
Function Code	An algorithm which manipulates specific functions. These functions are linked together to form the control strategy.
I/O Expander Bus	Parallel communication bus between the master and slave modules.
MFP	Multi-function processor module. A multi-loop controller with data acquisition and information processing capabilities.
MFT	Machine fault timer. Reset by the processor during normal operation. If not reset regularly, the MFT times-out and the module stops.
MMU	Module mounting unit. A card cage that provides electrical and communication support for INFI 90/Network 90 [®] modules.
Module Bus	Peer-to-peer communication link used to transfer information between intelligent modules within a process control unit.
Node	A point of interconnection to a network.
PCU	Process control unit. A node on the plant-wide communication network containing control and I/O modules.

[®] Network 90 is a registered trademark of Eltag Bailey Process Automation.

Table 1-3. Glossary of Terms and Abbreviations (continued)

Term	Description
SAC	Analog control station.
Termination Module	Provides input/output connection between plant equipment and the INFI 90/Network 90 modules.
Termination Unit	Provides input/output connection between plant equipment and the INFI 90/Network 90 modules.

SPECIFICATIONS

Refer to Table 1-4 for the specifications of the IMMFP01 Multi-Function Processor Module.

Table 1-4. Specifications

Property	Characteristic/Value
Microprocessor	32-bit processor (16-bit external bus) running at 16 MHz
Memory	
Total	512 kbytes ROM 256 kbytes RAM 64 kbytes NVRAM
Available	163,248 bytes RAM 62,656 bytes NVRAM
Power Requirements	+5 VDC @ 2 A; 10 W typical
Serial Ports	Two RS-232-C ports, or one RS-485 and one RS-232-C port all of which link signals at a rate of up to 19.2 kbaud.
Station Support	Sixty-four 40-kbaud serial stations (IISAC01) or eight 5-kbaud serial stations (NDCS03 or NDIS01).
Redundant Communication Link Rate and Type	1 Mbaud serial link.
Electromagnetic/ Radio Frequency Interference	Values not available at this time. Keep cabinet doors closed. Do not use communication equipment any closer than 2 meters from the cabinet.
Programmability	C, BASIC, BATCH, ladder, function codes, and user-defined functions.
Dimensions	35.56 mm wide (1.40 in.) 177.80 mm high (7.00 in.) 298.45 mm long (11.75 in.)
Mounting	Occupies one slot in a standard INFI 90 module mounting unit.
Ambient Temperature	0° to 70°C (32° to 158°F)
Relative Humidity	5% to 95% up to 55°C (131°F)(noncondensing) 5% to 45% above 55°C (131°F)(noncondensing)
Atmospheric Pressure	Sea level to 3 km (1.86 mi)
Air Quality	Noncorrosive
Certification	CSA certified for use as process control equipment in an ordinary (non-hazardous) location. Factory Mutual approved for use in Class I, Division 2, hazardous locations.

SECTION 2 - DESCRIPTION AND OPERATION

INTRODUCTION

The IMMFP01 Multi-Function Processor Module functions like a series of functional blocks working together. To explain how the MFP module works, this section shows MFP module functionality as a block diagram (see Figure 2-1) and then explains each block in the following text.

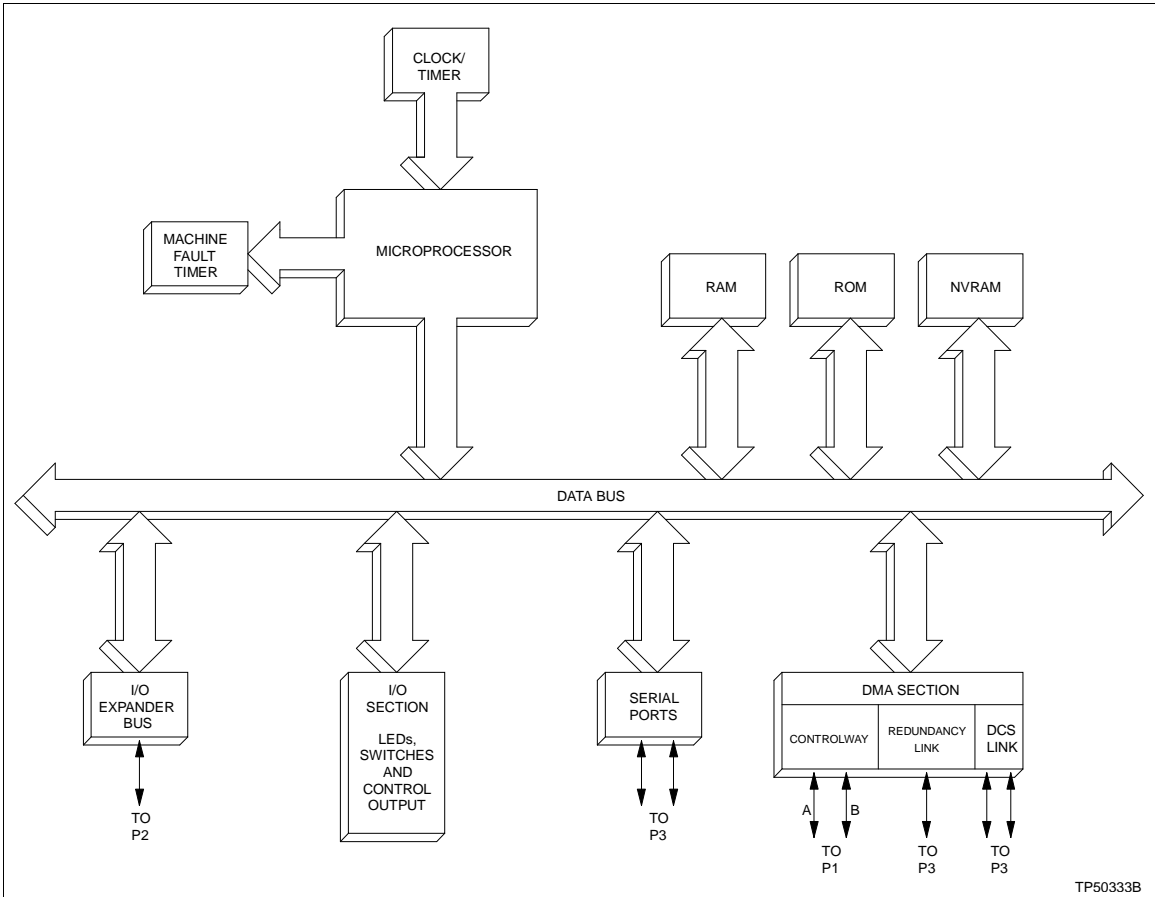

Figure 2-1. IMMFP01 Module Functional Block Diagram

MICROPROCESSOR

The microprocessor, operating at 16 megahertz, enables module operation and control. The operating system instructions and function code library of the microprocessor reside in read only memory (ROM). Since the microprocessor is responsible for overall module operation, it communicates with all the functional blocks. The microprocessor also constantly triggers the machine fault timer (MFT) circuit. If the microprocessor or module software fails and the MFT circuit is not reset, the MFT

circuit issues a board-wide reset and the status LED turns red. This condition is known as a fatal error.

CLOCK AND TIMER

The clock section provides the clock signals that drive the module at 16 megahertz. Additionally, this section supplies the lower order clock signals for the on-board serial links, and the system timer for uniform control algorithm execution. All clock signals originate from either the 32-megahertz or 7.3728-megahertz oscillators on the multi-function processor module.

The timer section keeps the multi-function processor module task scheduling at the proper intervals. One of the UART devices used for serial communication contains the timer section.

MEMORY

The MFP module contains 512 kilobytes of ROM memory, 256 kilobytes of random access memory (RAM) and 64 kilobytes of nonvolatile random access memory (NVRAM). It is important to remember that only 163,248 bytes of RAM memory and 62,256 bytes of NVRAM memory are available for user configurations. The ROM memory holds the operating system instructions for the microprocessor. The RAM memory provides temporary storage and a copy of the modules configuration. The NVRAM memory holds the module configuration (control strategy designed with function codes). The ability to retain information when power is lost makes this type of memory unique. Back-up batteries in the NVRAM device that keep the memory active makes this possible.

A key feature of the RAM and ROM memory of the MFP module is that it requires only one wait state. This means that the microprocessor need only wait one clock cycle before it can check the data in memory. This results in quicker operation.

I/O EXPANDER BUS

The I/O expander bus resides on the backplane of the module mounting unit. This bus, an eight-bit parallel bus, provides the communication path for I/O data between control and I/O modules. It supports up to 64 low power I/O modules. The bus uses a protocol designed by Bailey Controls Company to insure data integrity. The bus bandwidth is 500 kilobytes per second, however actual throughput is about 100 kilobytes per second.

I/O SECTION

The input and output section interface allows the microprocessor to read the switches that tell it how to operate and what

address it has. This section contains the latches whose outputs connect to LEDs one through eight and the status LED. Additionally this section contains an output that designates this module as the primary module. Upon a failover, this output turns off and the backup module output energizes as it takes over. This output actuates an LED that indicates which module is the primary.

Additionally, the input and output section monitors the stop/reset pushbutton. Pressing the pushbutton once causes this section to bring the module to an orderly stop after completing any input or output function currently in progress. Pressing the pushbutton a second time resets the module.

SERIAL CHANNELS

The MFP module contains two independent, general purpose serial channels. One use is for language support (C and BASIC). Each channel supports standard baud rates up to 19.2 kilobaud. The appropriate termination unit or termination module uses standard D-type connectors. The NTMP01, NIMP01, or NIMP02 termination device optically isolates these communication channels. This optical isolation eliminates the need to tie chassis ground to system common and alleviates the potential of damage from ground currents. One channel can also be used as a RS-485 connection.

DMA SECTION

The microprocessor sets this section for direct memory access or DMA. The DMA section allows data being received or transmitted over the various communication paths to be transferred directly to or from the RAM memory without microprocessor intervention. This process is known as cycle stealing. It greatly reduces the overhead associated with the microprocessor doing such data moves. This circuitry is used for the higher speed communication paths where the microprocessor would be overloaded handling the data moves, specifically Controlway. The 40-kilobaud station link and the redundancy link also use this feature.

CONTROLWAY

The Controlway is the high-speed version of the module bus. It provides a one-megabaud peer-to-peer communication link capable of supporting up to 32 connections. The Controlway interface is provided by a custom Bailey Controls integrated circuit that links the MFP module to the Controlway. It has full DMA capabilities (allowing for quicker operation), and two redundant, independent communication channels.

There are two separate communication paths on the MMU backplane circuit allotted for Controlway communications. Data is transmitted over both channels simultaneously and received in separate receivers where it is checked for integrity. In this way, the Controlway minimizes the chances that a failure on a circuit board or the backplane will cause loss of module communication.

As point data between intelligent modules travels on the bus, the MFP module does a bit-by-bit comparison. The Controlway interface also allows the MFP module to operate on the module bus by operating in an 83.3-kilobaud mode.

REDUNDANCY LINK

The redundancy link is a one-megabaud serial link between a primary and backup MFP module in a redundant configuration. This link also has full DMA capabilities. As the primary module executes control algorithms, the backup module waits in hot standby mode and receives a copy of all block outputs over this link. If for any reason, the primary module fails, the backup module takes over immediately without any process interruption provided there is no excessive checkpoint overrun caused by the function block configuration.

NOTE: Firmware revision levels must be the same in both primary and secondary MFP modules. If the firmware revision level is different and a failover occurs, the redundant MFP module may operate erratically.

STATION LINK

The station link controls the serial communication between the MFP module and stations. This link has two modes of operation. When used with the NDCS03 Digital Control Station, it provides a five-kilobaud serial channel for up to eight stations. This link connects to the NTMP01 termination unit via the NKSE01 or NKSE11 cable. This link requires serial link wire to connect to NIMP01 and NIMP02 termination modules.

When interfacing with the IISAC01 Analog Control Station, the communication rate can be five kilobaud or 40 kilobaud and the data is direct memory accessed into or out of MFP module memory. The 40-kilobaud link supports up to 64 stations, but requires two drivers to accomplish this. Therefore, two connectors provide for two NKSE01 cables and up to 32 stations can be driven off each. The data transmitted over both links is identical, so the stations must have an address from zero to 63 without duplication. The five-kilobaud link supports up to eight stations.

SECTION 3 - INSTALLATION

INTRODUCTION

This section explains what must be done before placing the multi-function processor module into operation. Read, understand, and complete the steps in the order they appear before operating the MFP module.

NOTE: To avoid potential module damage, evaluate your system for compatibility prior to module installation. This module uses connections to the module mounting unit backplane that served other functions in early Network 90 systems.

Early Network 90 systems applied -30 VDC to pins 3 and 4 of the module connector P1. This voltage is not required for INFI 90 modules. In INFI 90 systems, pin 4 is used for the Controlway bus.

If your system contains modules that require -30 VDC, set jumper J5 to the 30 VDC position. Doing so allows the installation of the MFP in a module mounting unit that uses -30 VDC and limits communication to the module bus.

SPECIAL HANDLING

Observe these steps when handling electronic circuitry:

NOTE: Always use Bailey Controls field static kit (part number 1948385_1 - consisting of two wrist straps, ground cord assembly, alligator clip, and static dissipating work surface) when working with the modules. The kit is designed to connect the technician and the static dissipating work surface to the same ground point to prevent damage to the modules by electrostatic discharge.

1. **Use Static Shielding Bag.** Keep the modules in the static shielding bag until you are ready to install them in the system. Save the packaging for future use.
2. **Ground Bags before Opening.** Before opening a bag containing an assembly with semiconductors, touch it to the equipment housing or a ground to equalize charges.
3. **Avoid Touching Circuitry.** Handle assemblies by the edges; avoid touching the circuitry.
4. **Avoid Partial Connection of Semiconductors.** Verify that all devices connected to the module are properly grounded before using them.
5. **Ground Test Equipment.**

6. **Use Antistatic Field Service Vacuum.** Remove dust from the module if necessary.
7. **Use A Grounded Wrist Strap.** Connect the wrist strap to the appropriate grounding plug on the power entry panel. The grounding plug on the power entry panel is connected to the cabinet chassis ground.
8. **Do Not Use Lead Pencils to Set Dipswitches.** To avoid contamination of dipswitch contacts that can result in unnecessary circuit board malfunction, do not use a lead pencil to set a dipswitch.

UNPACKING AND INSPECTION

1. Examine the hardware immediately for shipping damage.
2. Notify the nearest Bailey Controls sales office of any such damage.
3. File a claim for any damage with the transportation company that handled the shipment.
4. Use the original packing material and container to store the hardware.
5. Store the hardware in an environment of good air quality, free from temperature and moisture extremes.

SETUP AND PHYSICAL INSTALLATION

This section explains how to configure and install the MFP module. After installing the MFP module, a function block configuration must be created to define the functions the module will perform. This configuration can be created in the module itself or can be created using a configuration tool (e.g., CAD/TXT, EWS).

The MFP module has two configurable dipswitches and five jumpers. Each dipswitch has eight poles. See Figure 3-1 for dipswitch and jumper locations. Dipswitch SW3 sets the bus mode and module address. Dipswitch SW4 sets module options and special operations (refer to the **Special Operations** portion of this section). Jumpers J1 through J5 are for special applications.

Dipswitch poles marked not used in tables must be kept in the zero position. The MFP module may not operate properly if these dipswitches are set to the one position. Since factory settings do not reflect default settings, it is imperative that all dipswitch settings be checked before putting the module into operation.

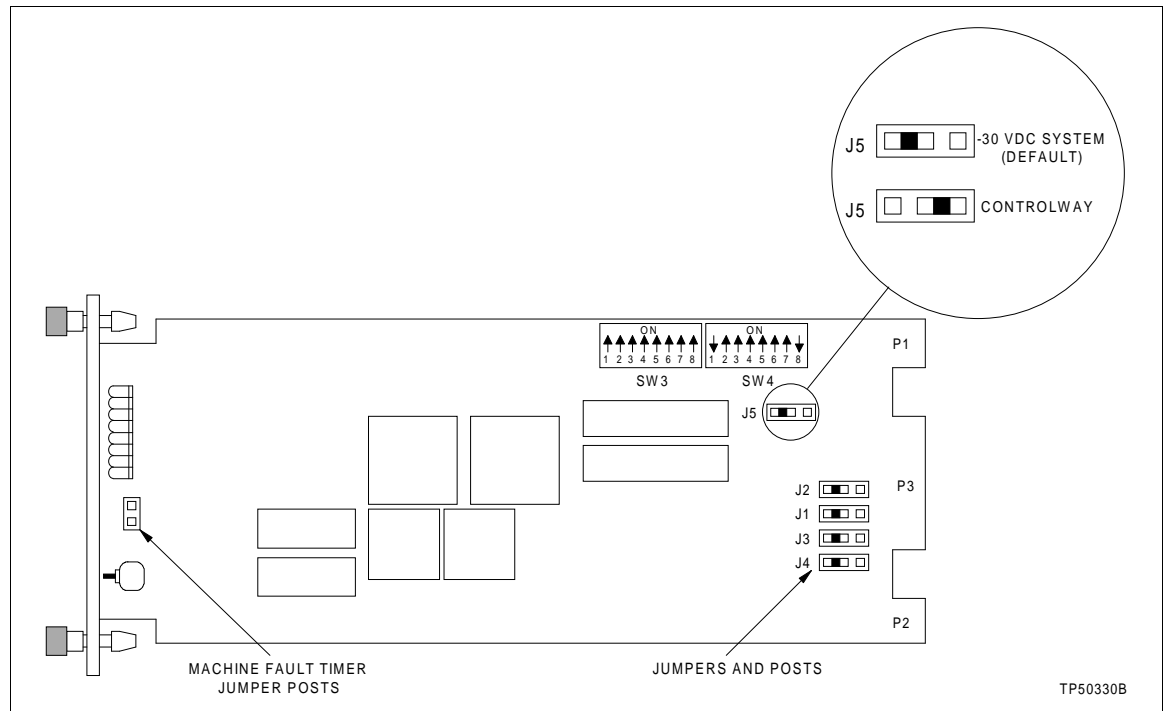

Figure 3-1. IMMFP01 Module Layout

Dipswitch SW3 Settings

Dipswitch SW3 sets the bus mode and address of the MFP module. The MFP module can have an address from zero through 31. Address zero and one should not be used because other MFP modules will not be able to import data from this MFP module. All MFP modules within a process control unit must communicate on the same communication highway (module bus or Controlway). Table 3-1 explains the function of each dipswitch pole. Table 3-2 shows some sample dipswitch settings. For quick reference, record your settings in the user setting portion of the table.

NOTE: Module addresses of redundant MFP modules must be identical. All modules within a process control unit must be set to communicate on either the Controlway or module bus.

Dipswitch SW4 Settings

Dipswitch SW4 enables the selection of a variety of module options. Refer to Table 3-3 for an explanation of the option settings. Refer to Section 5 of this instruction for the diagnostic switch setting information.

NOTE: Poles 1 through 7 on redundant MFP modules must be set to the same value

Table 3-1. IMMFP01 Dipswitch SW3 Settings

Pole	Setting	Function	User Setting
1	0	Normal run.	
	1	Invoke diagnostics using dipswitch SW4.	
2	0	Not used. Do not change setting.	
3 ¹	0	Controlway (1 Mbaud) mode.	
	1	Module bus (83.3 kbaud) mode.	
4 - 8	0 - 31	Controlway or module bus address.	

NOTE: 0 = CLOSED or ON, 1 = OPEN or OFF; shaded areas designate mandatory pole settings.
 1. Set jumper J5 for the same mode set by this dipswitch position.

Table 3-2. Example IMMFP01 Module Address Settings

Address Example	Dipswitch Position (Binary Value)				
	4 (16)	5 (8)	6 (4)	7 (2)	8 (1)
7	0	0	1	1	1
15	0	1	1	1	1
User Setting					

NOTE: 0 = CLOSED or ON, 1 = OPEN or OFF.

Table 3-3. IMMFP01 Dipswitch SW4 Normal Operation Settings

Pole	Setting	Function	User Setting
1	0	Disable special operations.	
	1	Enable special operations. Refer to Special Operations in this section for explanation.	
2	0	Disable on-line configuration.	
	1	Enable on-line configuration.	
3	0	Perform NVRAM checksum routine.	
	1	Inhibit NVRAM checksum routine. ¹	
4	0	Perform ROM checksum routine.	
	1	Inhibit ROM checksum routine. ¹	
5	0	Reserved for future options. Use this setting for normal operations even though it performs no function at this time.	
	1	Reserved for future options. Do not use this setting.	

Table 3-3. IMMFP01 Dipswitch SW4 Normal Operation Settings (continued)

Pole	Setting	Function	User Setting
6	0	Normal operation.	
	1	The compact configuration function moves configured function blocks to the top of the NVRAM memory while moving free space to the bottom. This condenses the configured function blocks while providing the largest possible area of contiguous unconfigured function blocks to the user. To enable this function, open the position and insert the module into the module mounting unit. After a short time period (directly proportional to the configuration size) the module will return to the mode it was in prior to being reset for the compact operation. ²	
7	0	Normal operation.	
	1	Initializes NVRAM (erase configuration) memory. To enable this function, open the pole and insert the module into the module mounting unit. When front panel LEDs 1, 2, and 4 are ON, remove the module, put the pole in the closed position, and insert the module. The module is now ready to be configured. NOTE: This pole must remain CLOSED for normal operation.	
8	0	Primary MFP module.	
	1	Redundant MFP module.	

NOTES: 0 = CLOSED or ON, 1 = OPEN or OFF; shaded areas designate mandatory pole settings.

1. Disabling the checksum routine is sometimes done by development personnel and should never be done for normal operation. The checksum routine provides additional module integrity and should be active whenever the module is controlling a process.

2. Leaving this option enabled causes the configuration to be compacted every time the module is reset thereby increasing the start-up time. This increase becomes more substantial as the size of the configuration increases. Therefore, do not leave this option enabled longer than necessary. Disabling this option stops any further compacting operations. It does not uncompact any previously compacted configuration.

Special Operations

The special operations feature provides a mechanism to configure the MFP module to do a one-time special operation rather than entering its normal mode of operation. Steps 1 through 8 explain how to set the MFP module for special operations and reset it for normal operation. Table 3-4 shows the dipswitch settings and explains each special operation.

Table 3-4. IMMFP01 Dipswitch SW4 Special Operation Settings

Special Operation	Dipswitch Position								Description
	1	2	3	4	5	6	7	8	
0	1	0	0	0	0	0	0	0	Reserved. Do not use this setting. Using this setting may cause the module to operate improperly.
1	1	0	0	0	0	0	0	1	Reserved for future options. Not used at this time.
2	1	0	0	0	0	0	1	0	Initializes NVRAM configuration space and format the module for Plant Loop operation.
3	1	0	0	0	0	0	1	1	Reserved. Do not use this setting. Using this setting may cause the module to operate improperly.

Table 3-4. IMMFP01 Dipswitch SW4 Special Operation Settings (continued)

Special Operation	Dipswitch Position								Description
	1	2	3	4	5	6	7	8	
4	1	0	0	0	0	1	0	0	Enables INFI-NET [®] protocol. This allows exception reporting from function blocks numbered 1024 or greater.
5	1	0	0	0	0	1	0	1	Permit segment modification (allows change to segment scheme configured with function code 82, specification S1).
6	1	0	0	0	0	1	1	0	Enable time stamping. This operation instructs the MFP module to generate time information with point data. It is applicable only to INFI-NET systems.

NOTE: 0 = CLOSED or ON, 1 = OPEN or OFF.

To execute special operations:

1. Set pole 1 of dipswitch SW4 to the open (off) position.
2. Set poles 2 through 8 for the desired operation in accordance with Table 3-4.
3. Insert the module into its assigned slot in the module mounting unit.
4. When the special operation is complete, the module status LED turns red and LEDs 1 through 6 illuminate.
5. Remove the module.
6. Repeat Steps 2 through 5 for any other desired special operation.

NOTE: Special operation 2 should be done as the first step of the installation process. When installing the MFP module in an INFI-NET system, do special operation 4 next. If time stamping is desired, do special operation 6 next. To reverse the INFI-NET protocol or time stamping, do special operation 2 again.

7. Set pole 1 to the closed (on) position.
8. Set poles 2 through 8 in accordance with Table 3-3.
9. Insert the module into its assigned slot. The module will enter configure mode.

Jumpers J1 through J5

There are five jumpers on the MFP circuit board. See Figure 3-1 for jumper locations. Jumpers J1 through J4 direct signals to the termination unit or module. These jumpers are factory set with pin 1 and pin 2 connected together. **Do not change these jumper settings.** Jumper J5 enables the MFP module to

[®] Registered trademark of Eltag Bailey Process Automation.

operate in module mounting units that use -30 VDC. Refer to Table 3-5 for more information.

NOTE: Two unlabeled jumper pins are located at the front of the board. These are for Bailey Controls development personnel usage only. They are used to disable the machine fault timer circuit. If this function is disabled and a problem develops in the MFP module, the module will not halt. This condition may result in configuration corruption and unpredictable module outputs.

PREPARING THE MODULE MOUNTING UNIT

Preparing the module mounting unit consists of identifying the proper slots, installing the required dipshunts, and verifying the Controlway or module bus cable is installed.

Table 3-5. IMMFP01 Jumper J1 through J5 Settings

Jumper	Setting	Function	User Setting
J1	1-2	Factory setting. Do not change this setting.	
J2	1-2		
J3	1-2		
J4	1-2		
J5	1-2	Disconnects Controlway for operation in module mounting units that have -30 VDC (early Network 90).	
	2-3	Allows operation in module mounting units that have Controlway communication. This setting must be used if dipswitch SW3 selects the Controlway.	

NOTE: Shaded areas designate mandatory jumper settings.

Dipshunts

WARNING	Disconnect power before installing dipshunts on the module mounting unit backplane. Failure to do so will result in contact with cabinet areas that could cause severe or fatal shock.
AVERTISSEMENT	Interrompez l'alimentation avant d'installer des dipshunts sur le fond de panier du châssis de montage des modules. Sinon, tout contact avec cette zone entraîne des risques d'électrocution sérieuse ou fatale.

Verify that 24-pin dipshunts are in place between all module slots on the I/O expander bus associated with one MFP module. One dipshunt goes between each module slot to maintain continuity. Remove any dipshunts that would connect the MFP module to any module slots not associated with the MFP module.

Controlway Cable

Install the Controlway or module bus cable in INFI 90 module mounting units as follows:

1. Attach one end of the Controlway or module bus cable (twisted 3-wire) to the bottom 3 tabs on the lower left of the MMU backplane (facing from behind). See Figure 3-2.
2. Attach (in the same sequence) the other end of the cable to the bottom 3 tabs on the lower left of the next module mounting unit backplane.

NOTE: Due to high speed constraints, a maximum of 8 related (Controlways linked by cable) module mounting units can be installed in 1 cabinet. The number of interconnected module mounting units (Controlway or module bus) should be kept to a minimum to avoid crosstalk and interference. You cannot cable link Controlways in separate cabinets.

INSTALLING THE TERMINATION UNIT OR MODULE

Refer to the NTMP01 termination unit product instruction or the NIMP01 and NIMP02 termination module product instruction for information about how to install and connect communication and power wiring to these termination devices. The following is a general introduction to termination unit or module installation.

NTMP01 Termination Unit Installation

1. Configure the jumpers on the termination unit. Refer to [Appendix C](#) for quick reference or to the appropriate product instruction for detailed information on jumper settings and applications.

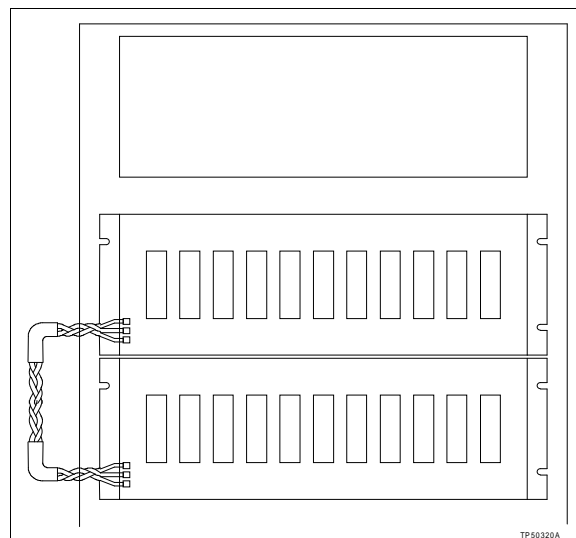

Figure 3-2. Controlway Cable Installation

2. Install the termination unit on the termination unit panel and secure into place.
3. Connect the hooded end of the NKTU01 or NKTU11 cable to the rear of the module mounting unit slot assigned to the MFP module.
4. Connect the other end of the cable to the P1 connector on the termination unit. For redundant modules, connect the other end of the cable to the P2 connector on the termination unit.

NIMP01 or NIMP02 Termination Module Installation

1. Configure the jumpers on the termination module. Refer to [Appendix D](#) for quick reference or to the appropriate product instruction for detailed information on jumper settings and applications.
2. Connect one end of the NKTU02 or NKTU12 cable to the rear of the termination mounting unit.
3. Connect the other end of the cable to the rear of the module mounting unit slot assigned to the MFP module.
4. Push the termination module into the termination mounting unit until it seats in the termination module connector.

INSTALLING THE MODULE

CAUTION	Never operate the MFP module with the machine fault timer circuit disabled (jumper pins connected). Unpredictable module outputs and configuration corruption may result. The unpredictable module outputs may damage control equipment connected to the MFP module.
ATTENTION	N'utilisez jamais un module MFP sans l'usage de sa minuterie de détection de défaillance (MFT) (c'est à dire avec le cavalier en place). Les sorties du module pourraient prendre des valeurs ou des états imprévisibles, et la configuration pourrait être corrompue. Le comportement imprévisible des sorties pourrait endommager le matériel de commande relié au module MFP.

To determine if the module mounting unit uses -30 VDC:

1. Locate the -30 VDC faston. It is the second faston from the top when viewing the module mounting unit from the rear.

2. Check for -30 VDC with respect to system common at the -30 VDC faston.
3. If -30 VDC is present, set jumper J5 and dipswitch SW3 to the appropriate positions.

Before installing the MFP module:

1. Check all module dipswitch and jumper settings (normal and special operation)
2. Insure that respective module cables are attached to their proper slot in the module mounting unit backplane.

CAUTION

To avoid potential module damage, evaluate your system for compatibility prior to module installation. This module uses connections to the module mounting unit backplane that served other functions in early Network 90 systems.

ATTENTION

Pour éviter d'endommager des modules, évaluez la compatibilité de votre système avant de les y brancher. L'usage que fait ce module de certaines connexions au fond de panier du châssis de montage diffère de l'assignation prévue par le système Network 90 original.

To install the MFP module:

1. Guide the top and bottom edges of the module along the top and bottom rails of their assigned slot in the module mounting unit.
2. Push on the faceplate until the rear edge of the module is firmly seated in the backplane connectors.

NOTE: If installing the MFP module under power, verify the status LED illuminates red momentarily and then illuminates green. If these events do not occur, refer to [Section 5](#) for corrective action.

3. Turn the 2 latching screws 1/2-turn to lock the module in place. The module is locked in place when the open end of the slots on the latching screws face the center of the faceplate.

SECTION 4 - OPERATING PROCEDURES

INTRODUCTION

This section explains what happens to the IMMFP01 Multi-Function Processor (MFP) Module during start-up, the LED indicators and what they mean, how to stop or reset the module, and the three modes of operation.

START-UP

When power is applied to the MFP module, the module does an internal hardware check, checks its configuration and builds the necessary databases.

During start-up of primary modules, the front panel LEDs will go through the following sequence:

1. All front panel LEDs will illuminate red.
2. The status LED will change from red to green.
3. LEDs 1 through 6 will turn off.

During start-up of secondary modules, the front panel LEDs will go through the following sequence:

1. All front panel LEDs will illuminate red.
2. The status LED will change from red to green.
3. All LEDs will turn off.
4. LED 7 will illuminate red and then turn off.
5. LED 8 will illuminate red.

If the appropriate LEDs do not illuminate, refer to [Section 5](#) for more details.

LED INDICATORS

There are nine LEDs visible through the faceplate window. Eight CPU LEDs reflect the on-board microprocessor status. The status LED, located above the CPU LEDs, reflects the over-all module status. See [Figure 4-1](#) for the exact location of the LEDs.

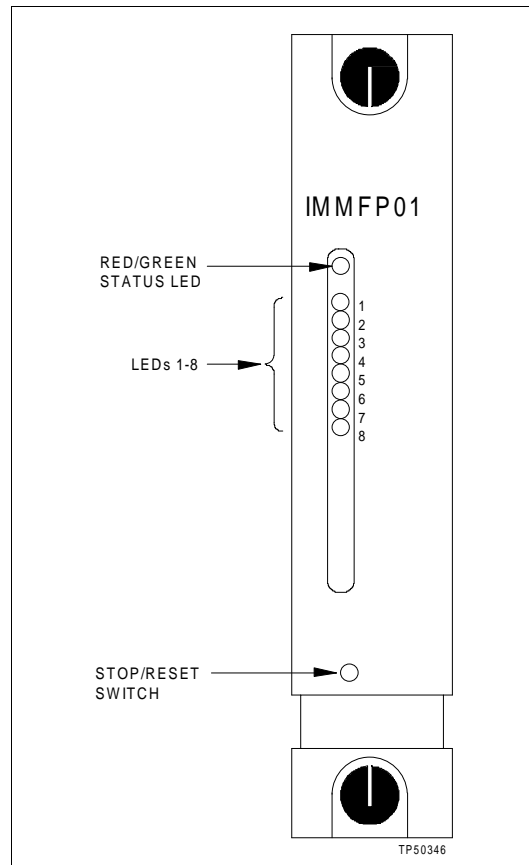

Figure 4-1. IMMFP01 Front Panel LEDs and Controls

Front Panel LEDs One through Eight

These LEDs indicate MFP module error codes. In redundant configurations, these LEDs also designate the primary MFP module and the secondary MFP module. LEDs seven and eight illuminate on the primary module. Only LED eight illuminates on the secondary module. If an error occurs, the status LED may start flashing or change from green to red and LEDs one through eight illuminate in a certain sequence. This sequence corresponds to an error code. Refer to Table 5-1 to interpret the error code. Please note that LEDs one through eight illuminate during module start-up. This is normal operation and means that the module is not yet on-line.

Red/Green Status LED

The status LED is a two color (red and green) LED. It shows the MFP module operating condition. There are four possible operating conditions:

- Off** No power is being supplied to the MFP module. The status LED is momentarily off when microprocessor initializes on start-up.

Solid Green	The MFP module is in execute mode.
Flashing Green	The MFP module is in execute mode but there is an NVRAM checksum error, or the MFP module is in configure or error mode.
Solid Red	The MFP module diagnostics have detected a hardware failure, configuration problem, etc. and has stopped the module. Additionally, LEDs one through eight will illuminate in a certain combination to display the error code.

STOP/RESET SWITCH**NOTES:**

1. Do not remove an operational MFP module under power unless the stop/reset pushbutton has been depressed once and the module has halted (status LED is red and LEDs 1 through 6 are on). This procedure must be followed when removing an MFP module from a redundant configuration. An operational primary MFP module must halt operation before control passes to the secondary MFP module.
2. Firmware revision levels must be the same in both primary and secondary MFP modules. If the firmware revision levels are different and a failover occurs, the redundant MFP module may operate erratically.

The stop/reset switch is a two-function switch. It stops the module in an orderly manner thereby preventing glitches on the bus. It also resets the MFP module. This switch is accessible through the opening on the faceplate. See Figure 4-1 for the exact location of the opening. Since the opening is small, pressing the switch requires a thin round object. Pressing the switch once stops MFP module operation. Always stop an MFP module before removing it from the module mounting unit. Stopping the MFP module in this way causes the module to:

- Save and lock the MFP module configuration.
- Complete any nonvolatile memory write operations in progress.
- Deactivate all communication links.
- Transfer control from the primary module to the secondary module in redundant configurations.
- Change the status LED color to red.

Once the MFP module is stopped, pressing the stop/reset switch again resets the module. Reset the module to:

- Reset the default values to the power-up values.

- Recover from a module time-out or operator-initiated stop.

NOTE: Pressing and holding the stop/reset switch provides no additional functionality over pressing and releasing the switch. To stop the module, press and release the stop/reset switch. To reset the module, press the stop/reset switch a second time. If the module halts due to an error (causing the status LED to turn red), a single push of the stop/reset switch resets the module.

MODES OF OPERATION

The MFP module has three operating modes. They are configure, execute, and error. These modes are explained in the following paragraphs.

Configure Mode

Use the configure mode to enter control strategies. The MFP module receives configuration commands over Controlway or module bus and changes the data in the NVRAM memory.

NOTE: The process of configuring the MFP module requires information from at least two documents. The first document is the **FUNCTION CODE APPLICATIONS MANUAL**. This contains all of the information needed to design a control strategy. The second document is the instruction manual for the particular configuration tool (e.g., CAD/TXT EWS) being used. This instruction manual explains the steps required to download control strategies into the MFP module memory.

Execute Mode

The execute mode is the normal mode of operation. In this mode, the MFP module communicates with I/O modules and other control modules. The MFP module also processes exception reports, configuration messages, and control messages. It executes control configurations, reads inputs, and updates outputs.

Error Mode

The MFP module goes into the error mode whenever the built-in system diagnostics detect a hardware or configuration error. If a hardware error is detected, the module halts and displays the error code using LEDs one through eight. If a NVRAM error is detected, the status LED flashes, but the module continues to operate. This is possible because a copy of the valid configuration is held in RAM memory and is executed from there. The next time the module is reset it will not start up, but will fail with a NVRAM error.

SECTION 5 - TROUBLESHOOTING

INTRODUCTION

This section contains information on the LED error codes, miscellaneous LED states, and diagnostic functions. Table 5-1 lists MFP module error codes, their meaning, and possible corrective actions. Table 5-2 lists all other possible LED states. The flowcharts in Figures 5-1 and 5-2 provide a quick reference guide to the front panel error codes and possible corrective actions.

Table 5-1. IMMFP01 Module Error Codes

Code	LED								Condition	Corrective Action
	8	7	6	5	4	3	2	1		
01	0	0	0	0	0	0	0	1	NVRAM memory checksum error	Initialize NVRAM. If error recurs, replace the MFP module. If the error recurs, call Bailey field service.
02	0	0	0	0	0	0	1	0	Analog input calibration error	Check status bytes 4 and 5 of your IMCIS02, IMASO01, or IMASO03 module for an invalid reference.
03	0	0	0	0	0	0	1	1	Auxiliary module status bad	Check the status bytes of the auxiliary module for more information.
05	0	0	0	0	0	1	0	1	Configuration error (undefined block is referenced)	Check the configuration for any faulty block references and correct any found. Execute the configuration after making the corrections.
06	0	0	0	0	0	1	1	0	Configuration error (data type mismatch)	Check the configuration for any command referencing an invalid data type. Execute the configuration after making the corrections.
08	0	0	0	0	1	0	0	0	Trip block activated	Review the configuration to determine why the TRIP function code in the configuration has stopped the MFP module.
0B	0	0	0	0	1	0	1	1	NVRAM memory initialized	Confirm that NVRAM is initialized; no action is required.
0C	0	0	0	0	1	1	0	0	NVRAM memory opened for write operation	Initialize the NVRAM memory. If the error recurs, replace the MFP module. If the error recurs, call Bailey field service.
0D	0	0	0	0	1	1	0	1	Redundancy link communication error	Check the cable connection between primary and secondary MFP modules. Check the cable connection from MFP module to the termination unit or module.
0E	0	0	0	0	1	1	1	0	Redundant module IDs are the same	Place pole 8 of dipswitch S4 in the opposite position of dipswitch S4 pole 8 of the primary module.

Table 5-1. IMMFP01 Module Error Codes (continued)

Code	LED								Condition	Corrective Action
	8	7	6	5	4	3	2	1		
0F	0	0	0	0	1	1	1	1	Primary module failed, configuration current, secondary module cannot take over control	Check the primary module configuration for any faulty values. Correct any faulty values. Execute the configuration after making the corrections.
10	0	0	0	1	0	0	0	0	Primary module failed, dynamic data current, secondary module cannot take over control	Check the primary module configuration for any faulty values. Correct any faulty values. Execute the configuration after making the corrections.
11	0	0	0	1	0	0	0	1	Error during write to NVRAM memory operation	Check the module configuration for any faulty values. Correct any faulty values. Execute the configuration after making the corrections.
12	0	0	0	1	0	0	1	0	Primary and secondary module addresses are different	Set both addresses to the same value. Refer to Section 3 for details.
13	0	0	0	1	0	0	1	1	ROM memory checksum error	Call Bailey field service.
14	0	0	0	1	0	1	0	0	MFP set for INFI-NET, when actually in a Plant Loop environment	Initialize the MFP module.
17	0	0	0	1	0	1	1	1	Duplicate Controlway module address	Select an unused Controlway address.
20	0	0	1	0	0	0	0	0	C program format error	Check, correct, and rerun the C program.
21	0	0	1	0	0	0	0	1	File system error	
22	0	0	1	0	0	0	1	0	Invoke C error	
23	0	0	1	0	0	0	1	1	User write violation	
24	0	0	1	0	0	1	0	0	C program stack overflow	
28	0	0	1	0	1	0	0	0	User defined function (UDF) block number reference invalid	Check the configuration for reference to invalid function block. Fix the block reference.
29	0	0	1	0	1	0	0	1	UDF function block cannot read program file	Check the configuration for invalid program location reference. Fix the UDF block.
2A	0	0	1	0	1	0	1	0	Not enough memory for UDF	Revise the configuration to provide more memory.
2B	0	0	1	0	1	0	1	1	Missing UDF declaration	Add function code 190 to configuration.
2C	0	0	1	0	1	1	0	0	Wrong UDF type	Put correct UDF type in configuration.
2D	0	0	1	0	1	1	0	1	Missing UDF auxiliary	Put function code 198 in block configuration.
2E	0	0	1	0	1	1	1	0	UDF compiler and firmware incompatible	Check the firmware revision level and verify that it supports UDF compiler.
2F	0	0	1	0	1	1	1	1	BASIC program error	Check, correct, and rerun the BASIC program.
30	0	0	1	1	0	0	0	0	Primary module active during failover attempt	Replace the primary and/or secondary module to determine the faulty module.
31	0	0	1	1	0	0	0	1	Memory or CPU fault	Replace the MFP module. If error recurs, call Bailey field service.

Table 5-1. IMMFP01 Module Error Codes (continued)

Code	LED								Condition	Corrective Action
	8	7	6	5	4	3	2	1		
32	0	0	1	1	0	0	1	0	Address or bus error	Reset MFP module. If error recurs, call Bailey field service.
33	0	0	1	1	0	0	1	1	Illegal instruction	
34	0	0	1	1	0	1	0	0	Internal error - trace/privilege violation	
35	0	0	1	1	0	1	0	1	Internal error - spurious/unassigned exception	
36	0	0	1	1	0	1	1	0	Internal error - divide by 0 or check instruction	
37	0	0	1	1	0	1	1	1	Any trap instruction	
38	0	0	1	1	1	0	0	0	Board level hardware error	Contact Bailey field service.
3F	0	0	1	1	1	1	1	1	Normal stop	None.
40	0	1	0	0	0	0	0	0	Backup - cold takeover ready	
80	1	0	0	0	0	0	0	0	Secondary - hot takeover ready	
C0	1	1	0	0	0	0	0	0	Primary - operating	
XX ¹									Unknown	Contact Bailey field service.

NOTE: 0 = LED OFF, 1 = LED ON.

1. This symbol represents any LED combination not specifically addressed in this table.

Table 5-2. IMMFP01 Module Error Codes

LED	Condition	Corrective Action
Status	OFF	Check power.
		Check module seating or try another module mounting unit slot.
		If power and seating are okay, remove the MFP module and replace with identically configured module.
	RED	Press stop/reset switch. If LED remains red, remove the MFP module and replace with identically configured MFP module.
	GREEN	None - normal.
7/8	OFF	Check power.
		Check module seating or try another module mounting unit slot.
		If power and seating are okay, remove the MFP module and replace with identically configured MFP module.
	RED	None - indicates primary module.
8	OFF	Check power.
		Check module seating or try another module mounting unit slot.
		If power and seating are okay, remove the MFP module and replace with identically configured MFP module.
	RED	None - indicates backup MFP module in redundant configuration.

NOTE: The conditions listed in this table are steady state conditions not transient or temporary conditions.

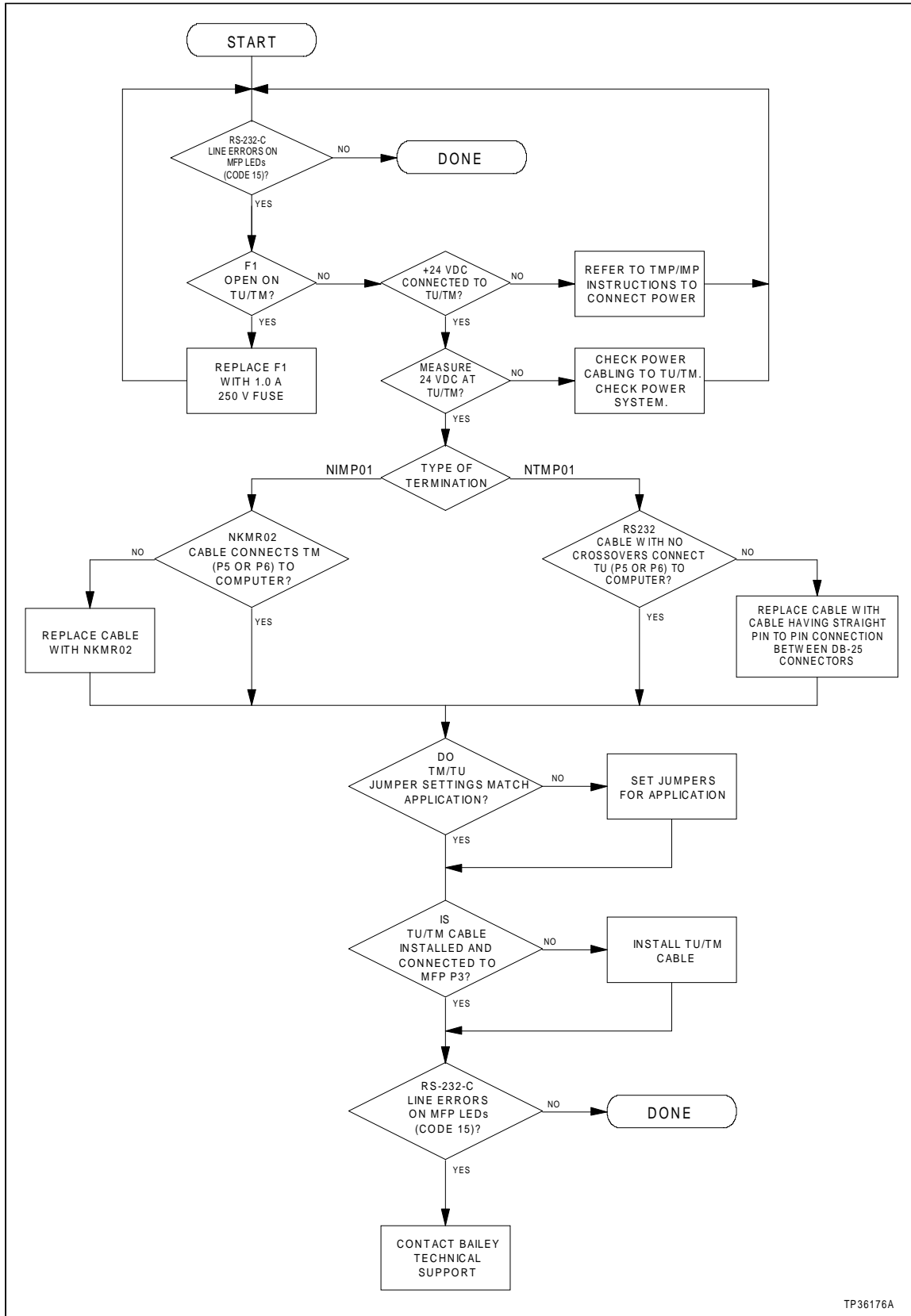

Figure 5-1. IMMFP01 Troubleshooting Flowchart (Serial Port)

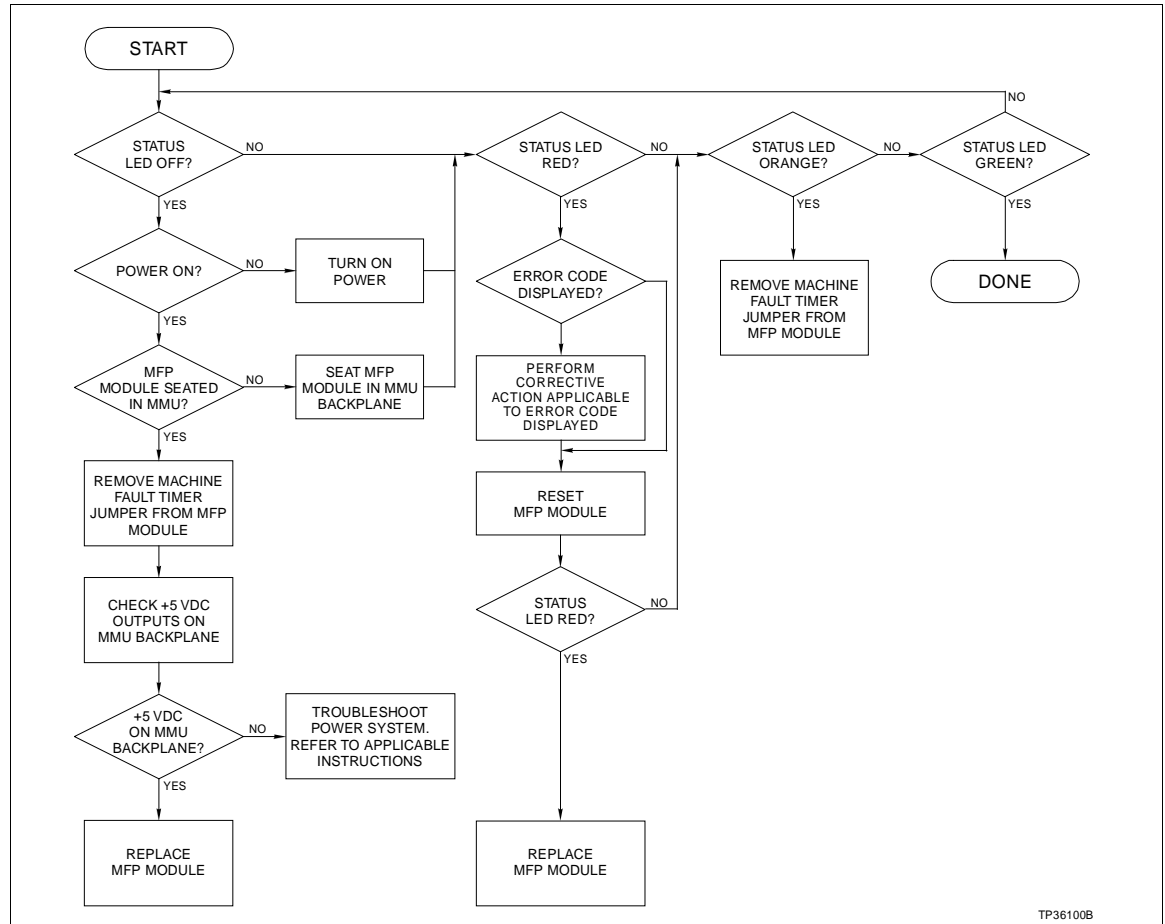

Figure 5-2. IMMFP01 Troubleshooting Flowchart (Status LED)

CARD EDGE CONNECTORS

Each MFP module has three card edge connectors that provide them with power and I/O. Tables 5-3, 5-4, and 5-5 list the MFP module card edge connector pin assignments.

Table 5-3. IMMFP01 Connector P1 Pin Assignments

Pin	Signal	Pin	Signal
1	+5 VDC	2	+5 VDC
3 ¹	Power Supply Status	4	Controlway B
5	Common	6	Common
7	+15 VDC	8	-15 VDC
9	Power Fail Interrupt	10	Unused
11	Controlway A/Module Bus	12	Unused

NOTE:

1. This pin will carry -30 VDC when the MFP module is used in -30 VDC Network 90 systems. This pin will carry the power supply status signal when the MFP module is used in newer Network 90 and INFI 90 systems.

Table 5-4. IMMFP01 Connector P2 Pin Assignments

Pin	Signal	Pin	Signal
1	Data Bit 1	2	Data Bit 0
3	Data Bit 3	4	Data Bit 2
5	Data Bit 5	6	Data Bit 4
7	Data Bit 7	8	Data Bit 6
9	Bus Clock	10	Synchronization
11	Reserved	12	Reserved

NOTE: All data bits are true low.

Table 5-5. IMMFP01 Connector P3 Pin Assignments

Pin	Signal	Pin	Signal
1	DCS A -	16	DCS A +
2	DCS B -	17	DCS B +
3	Redundancy Transmit -	18	Redundancy Transmit +
4	Redundancy Transmit Clock -	19	Redundancy Transmit Clock +
5	Redundancy Receive -	20	Redundancy Receive +
6	Redundancy Receive Clock -	21	Redundancy Receive Clock +
7	Receive A -	22	Receive A +
8	Receive B -	23	Receive B +
9	Clear to Send A -	24	Clear to Send A +
10	Clear to Send B -	25	Clear to Send B +
11	Transmit A -	26	Transmit A +
12	Transmit B -	27	Transmit B +
13	Request to Send A -	28	Request to Send A +
14	Request to Send B -	29	Request to Send B +
15	Digital Output +	30	Digital Output -

DIAGNOSTICS

The IMMFP01 Multi-Function Processor Module firmware contains diagnostic tests that can be invoked during module power-up. Putting the MFP module into the diagnostic mode allows the module to perform a variety of diagnostic tests but suspends normal operation. The diagnostic tests allow verification of the module components and circuitry. This section describes each diagnostic test and how to use it.

Overview

Select the required diagnostic test using the MFP module dipswitches. LEDs one through eight display the results of the test. Both group and individual tests can be executed.

The typical procedure is to select a diagnostic test to execute, set the module dipswitches accordingly, reset the module, and observe the results on LEDs one through eight. The selected test executes repeatedly until the MFP module is reset and another test is selected.

Some tests may require an additional module (an IMDSM05 slave module for the expander bus communication tests; an additional NTMP01, NIMP01, or NIMP02 termination device for the redundancy link and DCS link tests). Refer to Tables 5-6 and 5-7 for the IMDSM05 module configuration required for the expander bus communication tests.

Table 5-6. IMDSM05 Module Setup for IMMFP01 Tests

Dipswitch	Pole	1	2	3	4	5	6	7	8
S5		X	1	X	X	X	X	X	X
S4		X	X	0	0	1	1	1	1
S3		1	1	0	X	X	X	X	X

NOTE: 0 = CLOSED or ON, 1 = OPEN or OFF; X = Position not important.

Table 5-7. IMDSM05 Jumper Settings for IMMFP02 Tests

Jumper	Position
J17	2 - 3
J18	2 - 3

Dipswitch Selection

Set pole one of MFP dipswitch SW3 to one (open position) to put the module into the diagnostic mode. In diagnostic mode use the remaining poles to select module address and bus mode. Dipswitch SW4 selects the diagnostic test to be executed and how it will be executed. Figure 5-3 defines the function of each pole of dipswitches SW3 and SW4.

Pole one of dipswitch SW4 selects the LED display mode. The pass/fail display mode uses LEDs one through eight to display a combination of incrementing pass and fail counters. LEDs one through four indicate the number of passes successfully completed and LEDs five through eight indicate the number of failures. The test number display mode uses LEDs one through six to display the diagnostic test number and LED eight to display whether the test passed or failed. If a diagnostic test is successful, LEDs one through six display the diagnostic test number and LED eight does not illuminate. If a diagnostic test is not successful, LEDs one through six still display the diagnostic test number but LED eight will illuminate. LED seven is not used in test number display mode.

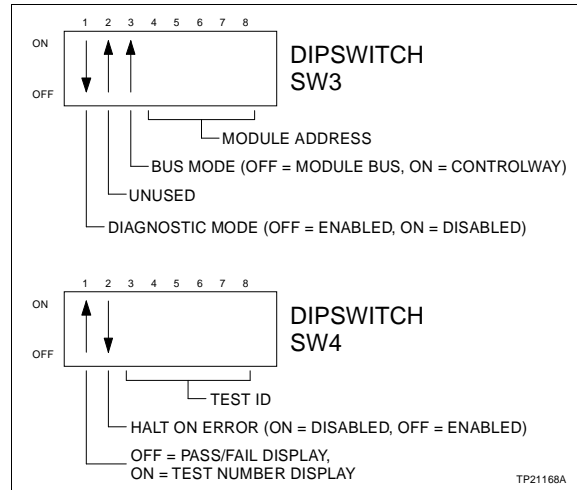

Figure 5-3. Diagnostic Dipswitch Settings

Pole two of dipswitch SW4 selects a halt on error feature. In this mode, the MFP module halts diagnostic test execution whenever the selected test detects an error. The front panel LEDs display the number of the failed test.

Poles three through eight of dipswitch SW4 select the diagnostic test to be executed. Pole eight is the least significant bit (binary weight 1) and pole three is the most significant bit (binary weight 32). Diagnostic test numbers can range from 00 (HEX) to 42 (HEX). Table 5-8 lists the available diagnostic tests and their number.

Table 5-8. Diagnostic Tests

Test Name	Test ID	Description
Switches and LEDs	00	Byte value of all dipswitches are exclusive OR'd together. Results are displayed on LEDs. Status LED is OFF for even or ON for odd total.
CPU	01	Verifies CPU instruction set is operational.
ROM	02	Calculates checksum of ROM memory and compares it to value stored in ROM memory during programming.
MMU	03	Exercises the on-board memory management unit.
RAM	04	Performs walking 1 test. Clears, verifies, sets and verifies all RAM memory. Test includes byte, word and long word accesses.
NVRAM	05	Verifies read and write function of NVRAM memory.
PLD	06	Loads programmable logic devices on the MFP module. Verifies proper loading and operation.
Password	07	Verifies firmware version is valid for current password stored in password PAL.
I/O Expander Bus Stall	08	Sets a latch enabling a level 7 interrupt to occur.
Module Bus/Controlway	09	Sends series of bytes to Controlway verifying timing and transfer status.

Table 5-8. Diagnostic Tests (continued)

Test Name	Test ID	Description
Timer IRQ	0A	Initializes DUART timer for 1-msec interrupts and then waits for it to time-out.
Dispatcher IRQ2	0B	Issues software dispatcher request and waits for interrupt to occur.
RS-232 DUART 0	0C	Tests (in local loopback mode) both serial channels of DUART circuitry.
DUART 1	0D	Tests (in local loopback mode) both serial channels of DUART circuitry that supports stations and redundancy links.
Unused	0E - 0F	—
Group Test 1	10	Executes tests 01 through 0F.
I/O Expander Bus Test ¹	11	MFP module performs status read and verifies the IMDSO05 module (address 15) responds over I/O expander bus. IMDSO05 LEDs count successful tests.
I/O Expander Bus Test IRQ3 Test	12	MFP module enables an interrupt level 3 and then writes a value to the I/O expander bus to initiate an interrupt.
SAC/DCS Link	13/23	Two MFP modules transmit and receive messages from each other over TU/TM redundancy link. Primary module test is 13. Backup module test is 23.
Redundancy Link	14/24	Two MFP modules transmit and receive messages from each other over TU/TM or NKMP03 redundancy link. Primary module test is 14. Backup module test is 24.
Unused	15 - 1F	—
Group Test 2	20	Executes tests 00 through 1F.
Null Test	21	Always passes.
IISAC01 and Redundancy Link Backup	22	Displays running count of bytes received by secondary MFP module when primary MFP module is executing test 20.
I/O Expander Bus Assassin Circuit Halt Test ²	25	Arms assassin circuit and allows I/O expander bus clock to stall.
NVRAM retention - data storage ²	26	Stores known data pattern in NVRAM memory.
NVRAM retention - data check	27	Verifies NVRAM memory holds data pattern stored in test 26.
NVRAM write lock ²	28	Verifies NVRAM memory write can be deleted when they are inhibited.
Stop pushbutton ³	29	Verifies proper pushbutton operation. A level 1 interrupt should occur when the pushbutton is pressed once.

NOTES:

1. Requires the IMDSM05 module. Refer to Table 5-6.

2. These tests are not continuous.

LED Display

The front panel LEDs (see Figure 5-4) are used during diagnostic mode operation to display test results.

Resetting the MFP module causes all eight LEDs (LEDs one through eight) to illuminate. Next, the module reads the dipswitches, executes the selected diagnostic test, and displays the test results using LEDs one through eight. The for-

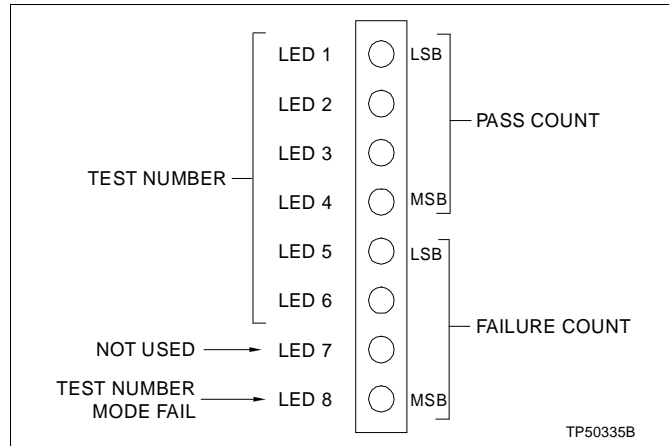

Figure 5-4. LEDs - Pass/Fail

mat of the LED display depends upon the setting of pole one of dipswitch SW4. If this pole is in the closed position, LEDs one through six display the diagnostic test number. LED eight illuminates if the test fails. This display format is visible for one fourth of a second, then the LEDs blank out for about one eighth of a second, and the test is repeated. If dipswitch SW4, pole one is in the open position, a running tally of successful and failed test executions will be displayed on the LEDs. LEDs one through four tally the successful executions and LEDs five through eight tally the failed executions.

If a test fails with halt-on error feature selected (dipswitch S4, pole one closed), the status LED turns red for approximately one second after the test status is displayed.

For group tests (diagnostic tests 10 (HEX) and 20 (HEX)), each test is run in numerical order. On a failure, the test number that failed is displayed when the test number display mode is selected. A failure of a test within the group terminates the group test at that point. All tests after the failing test in the group will not be run until the fault is removed.

MODULE STATUS SUMMARY

The multi-function processor module has a 16-byte module status record that provides summary flags for error conditions, module type, and firmware revision level. Table 5-9 shows the fields of the IMMFP01 module status report. Table 5-10 describes the fields of the module status report.

Refer to the operator interface station, management command system console, or engineering work station product instruction for an explanation of how to access the module status report.

Table 5-9. IMMFP01 Module Status Report

Byte	Bit							
	7	6	5	4	3	2	1	0
1	ES	MODE		MODULE TYPE				
2	FTX	BAC	RIO	LIO	CFG	NVF	NVI	DSS
3	Bytes 3-5 combine to define other errors. ¹							
4								
5								
6	Extended module type = 24							
7	CWA	CWB						
8 - 13	Reserved							
14	Nomenclature (decimal digit)							
15	Firmware revision level (ASCII letter)							
16	Firmware revision level (ASCII digit)							

NOTE: Refer to Table 5-10.

Table 5-10. Field Descriptions of the IMMFP01 Module Status Report

Field	Value	Description		
Byte 1				
ES	—	Error summary (0 = good, 1 = errors) ¹		
MODE	—	Module mode (00 = configuration, 01 = error, 11 = execute) ¹		
MODULE TYPE	—	Module type code (15 = enhanced status)		
Byte 2				
FTX	—	First time in execute (0 = no, 1 = yes) ¹		
BAC	—	Backup MFP status (0 = good, 1 = bad) ¹		
RIO	—	Summary remote I/O status (0 = good, 1 = bad) ¹		
LIO	—	Summary local I/O status (0 = good, 1 = bad) ¹		
CFG	—	On-line configuration changes being made (0 = no, 1 = yes) ¹		
NVF	—	NVRAM checksum error (0 = good, 1 = bad) ¹		
NVI	—	NVRAM default configuration (0 = no, 1 = yes) ¹		
DSS	—	Digital station status (0 = good, 1 = bad) ¹		
Bytes 3 through 5	3	4	5	
	01	01	—	NVRAM error: Write failure Checksum failure Bad data Reset during SP write Reset during write
	01	02	—	
	01	03	—	
	01	FA	—	
	01	FF	—	
	02	00	04	Analog input reference error: 1 V reference 5 V reference
02	00	05		

Table 5-10. Field Descriptions of the IMMFP01 Module Status Report (continued)

Field	Value	Description
Bytes 3 through 5 (continued)	3 4 5	
	03 <X> ² <Y> ²	Missing I/O module: XY = block no.
	05 <X> ² <Y> ²	Configuration error - undefined input: X = block no. making reference Y = block no. being referenced
	06 <X> ² <Y> ²	Configuration error - data type match: X = block no. making reference Y = block no. being referenced
	08 <X> ² <Y> ²	Trip block activated: X = block no. of trip block Y = block no. making reference
	0F — —	The primary MFP module has failed and the redundant MFP module configuration is not current.
	10 — —	The primary MFP module has failed and the SRAM data in the redundant MFP module is not current.
Byte 6	—	Extended module type: 24 = IMMFP01/IMMFP02/IMMFP03
Byte 7		
CWA	—	Controlway bus A (80 = failure)
CWB	—	Controlway bus B (40 = failure)
Byte 14	—	Nomenclature: 01 = IMMFP01 02 = IMMFP02 03 = IMMFP03
Byte 15	—	Revision letter ASCII letter
Byte 16	—	Revision number ASCII digit

NOTES:

1. These fields are expressed in binary format.
2. All block numbers are expressed in BCD.
3. All fields listed in this table are expressed in hexadecimal format unless otherwise specified.

SECTION 6 - MAINTENANCE

INTRODUCTION

WARNING	Wear eye protection whenever working with cleaning solvents. When removing solvents from printed circuit boards using compressed air, injury to the eyes could result from splashing solvent as it is blown off the printed circuit board.
AVERTISSEMENT	Portez toujours des lunettes de protection lorsque vous utilisez des solvants de nettoyage. L'air comprimé servant à enlever le solvant des cartes de circuits imprimés provoque des éclaboussures qui risquent d'atteindre les yeux.

The reliability of any stand-alone product or control system is affected by the maintenance of the equipment. Bailey Controls Company recommends that all equipment users practice a preventive maintenance program that will keep the equipment operating at an optimum level.

This section presents procedures that the customer should be able to perform on-site. These preventive maintenance procedures should be used as guidelines to assist you in establishing good preventive maintenance practices. Select the minimum steps required to meet the cleaning needs of your system.

Personnel performing preventive maintenance should meet the following qualifications.

- Maintenance personnel should be qualified electrical technicians or engineers that know the proper use of test equipment.
- Maintenance personnel should be familiar with the IMMFP01 Multi-Function Processor Module (MFP), have experience working with process control systems, and know what precautions to take when working on live AC systems.

PREVENTIVE MAINTENANCE SCHEDULE

Table 6-1 is the preventive maintenance schedule for the MFP module. The table lists the preventive maintenance tasks in groups according to their specified maintenance interval. Some tasks in Table 6-1 are self explanatory. Instruction for tasks that require further explanation are covered under **PREVENTIVE MAINTENANCE PROCEDURES**.

NOTE: The preventive maintenance schedule is for general purposes only. Your application may require special attention.

Table 6-1. Preventive Maintenance Schedule

Task	Frequency
Check cabinet air filters. Clean or replace them as necessary. Check the air filter more frequently in excessively dirty environments.	3 months
Check cabinet and MFP module for dust. Clean as necessary using an antistatic vacuum.	
Check all MFP module signal, power and ground connections within the cabinet. Verify that they are secure. Refer to the procedure.	
Check MFP circuit boards, giving special attention to power contacts and edge connectors. Clean as necessary. Refer to the procedure.	12 months
Complete all tasks in this table.	Shutdown

EQUIPMENT AND TOOLS REQUIRED

Listed below are tools and equipment required for maintenance:

- Antistatic vacuum.
- Clean, lint free cloth.
- Compressed air.
- Eberhard Faber (400A) pink pearl eraser or equivalent.
- Fiberglass or nylon burnishing brush.
- Foam tipped swab.
- Bladed screwdriver suitable for terminal blocks.
- Isopropyl alcohol (99.5% electronic grade).
- Natural bristle brush.

PREVENTIVE MAINTENANCE PROCEDURES

Tasks from Table 6-1 requiring specific instructions include:

- Printed circuit board cleaning.
- How to check signal, power and ground connections.

Printed Circuit Board Cleaning

There are several circuit board cleaning procedures in this section. These procedures cover circuit board cleaning and washing, cleaning edge connectors and circuit board laminate between edge connectors. Use the procedures that meet the needs of each circuit board. Remove all dust, dirt, oil, corrosion or any other contaminant from the circuit board.

Do all cleaning and handling of the printed circuit boards at static safe work stations. Observe the steps listed under **SPECIAL HANDLING** in Section 3 when handling printed circuit boards.

GENERAL CLEANING AND WASHING

If the printed circuit board needs minor cleaning, remove dust and residue from the printed circuit board surface using clean, dry, filtered compressed air or an antistatic field service vacuum cleaner.

Another method of washing the printed circuit board is:

1. Clean the printed circuit board by spraying it with isopropyl alcohol (99.5% electronic grade) or wiping the board with a foam tipped swab wetted in isopropyl alcohol.
2. When the circuit board is clean, remove excess solvent by using compressed air to blow it free of the circuit board.

EDGE CONNECTOR CLEANING

To clean edge connector contacts:

1. Use a solvent mixture of 80% isopropyl alcohol (99.5% electronic grade) and 20% distilled water.
2. Soak a lint-free cloth with the solvent mixture.
3. Work the cloth back and forth parallel to the edge connector contacts.
4. Repeat with a clean cloth that is soaked with the solvent mixture.
5. Dry the edge connector contact area by wiping with a clean lint free cloth.

To clean tarnished or deeply stained edge connector contacts:

1. Use an Eberhard Faber (400A) pink pearl eraser, or equivalent to remove tarnish or stains. Fiberglass or nylon burnishing brushes may also be used.
2. Minimize electrostatic discharge by using the 80/20 isopropyl alcohol and water solution during burnishing.
3. Do not use excessive force while burnishing. Use only enough force to shine the contact surface. Inspect the edge connector after cleaning to assure no loss of contact surface.

Checking Connections

Check all signal wiring, power and ground connections within the cabinet to verify their integrity. When checking connections, always turn a screw, nut or other fastening device in the

direction to tighten only. If the connection is loose, it will be tightened. If the connection is tight, the tightening action will verify that it is secure. There must not be any motion done to loosen the connection.

NOTE: Power to the cabinet must be off while performing this preventive maintenance task.

Check and verify that all cable connections are secure.

SECTION 7 - REPAIR/REPLACEMENT PROCEDURES

INTRODUCTION

Repair procedures are limited to module replacement. If the IMMFP02 Multi-Function Processor Module fails, remove and replace it with another. Verify that firmware revision levels match and that the replacement module switch and jumper settings are the same as those of the failed module.

MODULE REPLACEMENT PROCEDURE

Follow Steps 1 through 5 to replace the MFP module. Observe the steps listed in **SPECIAL HANDLING** in Section 3 when handling MFP modules.

NOTE: Do not remove an MFP module under power unless the stop/reset pushbutton has been depressed once and the module has halted (status LED is red and LEDs 1 through 6 are on). This procedure must be followed when removing an MFP module from a redundant configuration. An operational primary MFP module must halt operation before control passes to the secondary MFP module.

1. Turn the 2 latching screws 1/2-turn either way to release them.
2. Grasp the screws and pull the module out.
3. Set dipswitches SW3 and SW4 and jumper J5 on the replacement MFP module to match the settings of the removed MFP module.
4. Hold the MFP module by the faceplate and slide it into the slot; push until the rear edges are firmly seated in the back-plane connectors.
5. Turn the 2 latching screws 1/2-turn either way to lock the module into the module mounting unit.

TERMINATION UNIT OR MODULE REPLACEMENT PROCEDURES

To replace a NTMP01 Multi-Function Processor Termination Unit, NIMP01 Multi-Function Processor Termination Module, NIMP02 Multi-Function Processor Module, or termination cable, refer to the NTMP01, NIMP01, or NIMP02 instruction. These instructions contain step by step replacement procedures and spare parts information.

SECTION 8 - SUPPORT SERVICES

INTRODUCTION

Bailey Controls is ready to help in the use and repair of its products. Contact the nearest sales office to make requests for sales, applications, installation, repair, overhaul and maintenance contract services.

REPLACEMENT PARTS AND ORDERING INFORMATION

When making repairs, order replacement parts from a Bailey sales office. Provide this information:

1. Part description, part number and quantity.
2. Model and serial numbers (if applicable).
3. Bailey instruction manual number, page number and reference figure that identifies the part.

Order parts without commercial descriptions from the nearest Bailey Controls Company sales office.

Table 8-1. Spare Parts List

Description	Part Number
Jumper	1946984_1

NOTE: It is impractical to specify a recommended quantity of spare parts because Bailey custom designs every system. Contact Bailey Controls Company if you need help determining the quantity of spare parts you should keep on hand for your particular system.

TRAINING

Bailey Controls has a modern training facility available for training your personnel. On-site training is also available. Contact a Bailey Controls Company sales office for specific information and scheduling.

TECHNICAL DOCUMENTATION

Additional copies of this manual, or other Bailey Controls Company manuals, can be obtained from the nearest Bailey Controls Company sales office at a reasonable charge.

APPENDIX A - QUICK REFERENCE MATERIAL

INTRODUCTION

This appendix provides quick reference information to aid in the hardware configuration of the IMMFP01 Multi-Function Processor Module. Table A-1 and A-2 show the settings for dipswitches SW3 and SW4. Table A-3 shows the jumpers settings for jumper J5. Table A-4 is an abbreviated error code listings. Table A-5 shows other LED conditions.

Table A-1. IMMFP01 Dipswitch SW3 Settings

Pole	Setting	Function
1	0	Normal run.
	1	Enable diagnostics using dipswitch UMB1.
2	0	Not used. Do not change setting.
3	0	Controlway (1 Mbaud).
	1	Module bus (83.3 kbaud) used.
4 - 8	0 - 31	Controlway or module bus address mode.

NOTE: 0 = CLOSED or ON, 1 = OPEN or OFF.

Table A-2. IMMFP01 Dipswitch SW4 Settings

Pole	Setting	Function
1	0	Disable special operations.
	1	Enable special operations. Refer to Special Operations in Section 3 for explanation.
2	0	Disable on-line configuration.
	1	Enable on-line configuration.
3	0	Perform NVRAM checksum routine.
	1	Inhibit NVRAM checksum routine. ¹
4	0	Perform ROM checksum routine.
	1	Inhibit ROM checksum routine. ¹
5	0	Reserved for future options. Use this setting for normal operations even though it performs no function at this time.
	1	Reserved for future options. Do not use this setting.
6	0	Normal operation.
	1	The compact configuration function. ²
7	0	Normal operation.
	1	Initializes NVRAM (erase configuration) memory. NOTE: This position must remain CLOSED for normal operation.

Table A-2. IMMFP01 Dipswitch SW4 Settings (continued)

Pole	Setting	Function
8	0	Primary MFP module.
	1	Redundant MFP module.

NOTES: 0 = CLOSED or ON, 1 = OPEN or OFF; shaded areas designate mandatory pole settings.

1. Disabling the checksum routine is sometimes done by development personnel and should never be done for normal operation. The checksum routine provides additional module integrity and should be active whenever the module is controlling a process.

2. Leaving this option enabled causes the configuration to be compacted every time the module is reset thereby increasing the startup time. This increase becomes more substantial as the size of the configuration increases. Therefore, do not leave this option enabled longer than necessary. Disabling this option stops any further compacting operations. It does not uncompact any previously compacted configuration.

Table A-3. IMMFP01 Jumper J5 Settings

Jumper Position	Function
1 - 2	Allows the module to function in early Network 90 systems that supply -30 VDC. Communication is restricted to module bus in this position.
2 - 3	Allows communication over the Controlway or module bus.

Table A-4. IMMFP01 Module Error Codes

Code	LED							Condition		
	8	7	6	5	4	3	2		1	
01	0	0	0	0	0	0	0	1	NVRAM memory checksum error	
02	0	0	0	0	0	0	0	1	Analog input calibration error	
03	0	0	0	0	0	0	0	1	I/O module status bad	
05	0	0	0	0	0	0	1	0	1	Configuration error (undefined block is referenced)
06	0	0	0	0	0	0	1	1	0	Configuration error (data type mismatch)
08	0	0	0	0	1	0	0	0	0	Trip block activated
0B	0	0	0	0	1	0	1	1	1	NVRAM memory initialized
0C	0	0	0	0	1	1	0	0	0	NVRAM memory opened for write operation
0D	0	0	0	0	1	1	0	0	1	Redundancy link communication error
0E	0	0	0	0	1	1	1	1	0	Redundant module IDs are the same
0F	0	0	0	0	1	1	1	1	1	Primary module failed, configuration current, secondary module cannot take over control
10	0	0	0	1	0	0	0	0	0	Primary module failed, dynamic data current, secondary module cannot take over control
11	0	0	0	1	0	0	0	0	1	Error during write to NVRAM memory operation

Table A-4. IMMFP01 Module Error Codes (continued)

Code	LED								Condition
	8	7	6	5	4	3	2	1	
12	0	0	0	1	0	0	1	0	Primary and secondary module addresses are different
13	0	0	0	1	0	0	1	1	ROM memory checksum error
14	0	0	0	1	0	1	0	0	MFP set for INFI-NET, when actually in a Plant Loop environment
17	0	0	0	1	0	1	1	1	Duplicate Controlway module address
20	0	0	1	0	0	0	0	0	C program format error
21	0	0	1	0	0	0	0	1	File system error
22	0	0	1	0	0	0	1	0	Invoke C error
23	0	0	1	0	0	0	1	1	User write violation
24	0	0	1	0	0	1	0	0	C program stack overflow
28	0	0	1	0	1	0	0	0	User defined function (UDF) block number reference invalid
29	0	0	1	0	1	0	0	1	UDF function block cannot read program file
2A	0	0	1	0	1	0	1	0	Not enough memory for UDF
2B	0	0	1	0	1	0	1	1	Missing UDF declaration
2C	0	0	1	0	1	1	0	0	Wrong UDF type
2D	0	0	1	0	1	1	0	1	Missing UDF auxiliary
2E	0	0	1	0	1	1	1	0	UDF compiler and firmware incompatible
2F	0	0	1	0	1	1	1	1	BASIC program error
30	0	0	1	1	0	0	0	0	Primary module active during failover attempt
31	0	0	1	1	0	0	0	1	Memory or CPU fault
32	0	0	1	1	0	0	1	0	Address or bus error
33	0	0	1	1	0	0	1	1	Illegal instruction
34	0	0	1	1	0	1	0	0	Internal error - trace/ privilege violation
35	0	0	1	1	0	1	0	1	Internal error - spurious/unassigned exception
36	0	0	1	1	0	1	1	0	Internal error - divide by 0 or check instruction
37	0	0	1	1	0	1	1	1	Any trap instruction
38	0	0	1	1	1	0	0	0	Board level hardware error
3F	0	0	1	1	1	1	1	1	Normal stop
40	0	1	0	0	0	0	0	0	Secondary - cold takeover ready
80	1	0	0	0	0	0	0	0	Secondary - hot takeover ready
C0	1	1	0	0	0	0	0	0	Primary - operating
XX ¹									Unknown

NOTE: 0 = LED OFF, 1 = LED ON

1. This symbol represents any LED combination not specifically addressed in this table.

Table A-5. Other IMMFP01 Module LED Conditions

LED	Condition	Problem
Status	OFF	No power, improper module seating, or defective module.
	RED	Module not properly seated or module defective.
	GREEN	None - normal condition.
7/8	OFF	No power, improper module seating, or defective module.
	RED	None - indicates primary module.
8	OFF	No power, improper module seating, or defective module.
	RED	None - indicates backup module in redundant configuration.

APPENDIX B - ON-LINE CONFIGURATION

INTRODUCTION

Using on-line configuration in conjunction with redundant IMMFP01 Multi-Function Processor Modules enables making configuration changes without affecting the primary MFP module or interrupting the control process.

In redundant MFP module configurations, the primary MFP module executes the process control logic while the backup MFP module tracks the configuration of the primary. Using on-line configuration, it is possible to remove the backup (or secondary) module from the tracking mode and making configuration changes to it without interrupting the process control operation of the primary MFP module. The MFP module also supports conventional off-line changes. When the backup MFP module has been reconfigured, it can assume control with the new configuration while the original primary MFP module becomes the backup module.

During start-up of the new configuration in the backup module, it uses the current values of all process outputs in the primary module. This feature permits bumpless transfer of control to the new configuration.

SETUP

Redundant MFP modules must have two consecutive module bus or Controlway addresses (n and $n+1$ where n is the primary address, $n+1$ is the backup). Configure both modules of the redundant pair with the same module bus or Controlway address. In normal operation each module of the redundant pair has the same module bus or Controlway address as determined by the address dipswitch settings. (If the module bus or Controlway address of the redundant pair is set to four during normal operation, then automatically the module bus or Controlway address of the backup MFP module is set to five during on line configuration.)

OPERATION

This appendix provides a step by step procedure for performing on-line configuration. Use the configuration and tuning module, configuration tuning terminal, operator interface station console, management command system console, or engineering workstation with appropriate Bailey Controls Company configuration software to accomplish on-line configuration.

In some applications, MFP modules are remotely located prohibiting the operator from viewing the front panel LEDs. In these applications, use data from the second module status byte message to determine the status of the module. This appendix provides a procedure for on-line configuration that shows both the state of LEDs seven and eight as well as the contents of the second Module Status Byte message (specifically bits seven, six, three and one) for each step of the procedure. Refer to **Section 5** for the MFP module faceplate location of LEDs seven and eight.

The type of interface device used to connect the module bus or Controlway to the Plant Loop or INFI-NET determines how the module status is acquired. Using an operator interface station console, acquire the status by selecting the module in the PCU status display selected from the system status display. With an engineering work station using the Bailey Controls Company CAD/TEXT software package, select the problem report option. Please note that this option does not continuously poll for module status. It may be necessary to invoke this option multiple times until the final module status condition arises for the given step of the on-line configuration cycle. The Modify Mode menu of the CAD/TEXT software package contains the problem report option.

Do not reset a primary MFP module before the LEDs or module status byte of the backup MFP module indicates that it is available. Resetting the primary MFP module before verifying the backup module is available could result in unpredictable module operation or loss of output data.

Table **B-1** provides a legend of symbols necessary to fully understand this section. Table **B-2**, Figure **B-1**, Table **B-3** and Figure **B-2** illustrate the primary and backup cycles, respectively. For clarity, the term backup MFP module will always refer to the original backup MFP module and the term primary MFP module will always refer to the original primary MFP module. When the primary and backup roles are reversed for either unit, their status is carefully noted.

Table B-1. Legend of Symbols

Description	Primary	Backup
Module address	n	n+1
Second module status byte	Bit ¹ 7 6 5 4 3 2 1 0 0 1 x x 0 x 0 x	Bit ¹ 7 6 5 4 3 2 1 0 1 0 x x 1 x 0 x
LEDs 7 and 8 In the following tables, LED 8 is on top, LED 7 is on bottom	● ON ○ OFF	✱ BLINKING

NOTE:

- bit 7 = first time in execute (most significant bit (MSB)) x = position not important
 bit 6 = backup MFP module status bad 1 = bit set
 bit 3 = on-line configuration changes being made 0 = bit not set
 bit 1 = NVRAM default configuration

Backup Cycle

The step numbers in this cycle correspond to the status of Figure B-1.

Table B-2. Backup Cycle

Primary	Backup	Procedure
n 00xx0x0x ● ●	n+1 10xx0x0x ○ ●	1. Place the backup MFP module into execute mode. This saves a copy of the primary modules current configuration and enables it to be easily restored if needed.
n 01xx0x0x ● ●	n+1 00xx0x0x ○ ●	2. Place the backup MFP module in configure mode. The green LED of the backup MFP module blinks indicating configure mode. The module status also indicates configure mode. Configuration commands to the backup MFP module are sent to the address of the primary MFP module plus one (n+1). The primary MFP module now indicates that the backup MFP module is not available for automatic failover. Refer to bit 6 of the module status byte. To return to Step 1 without making any changes, place the backup MFP module in execute mode and reset it after LED 8 illuminates or the primary status indicates 00xx0x0x. Resetting an MFP module causes all the LEDs on it to light momentarily before returning to normal status.
n 01xx0x0x ● ●	n+1 00xx1x0x ✱ ○	When changes are being made to the backup MFP module, LED 7 blinks and bit 3 of the backup module status is set indicating that the configurations of the backup and primary MFP modules do not match. If these changes to the configuration are incorrect, return to Step 1 by initializing the backup MFP module NVRAM memory while it is in configure mode. NOTE: When configuring the backup MFP module, the following rules are strictly enforced by the module: <ul style="list-style-type: none"> • Blocks can only be added in the block space at segment end. • A block existing in the primary MFP module cannot be deleted. • A specification change cannot be made to a block already existing in the primary MFP module if that change will affect the module RAM utilization factor (change memory requirements). Any attempt to circumvent these rules will result in an appropriate error message.
n 01xx0x0x ● ●	n+1 00xx1x0x ✱ ○	3. When an error exists in the new configuration, the backup MFP module enters error mode when attempting to transfer to execute mode. Return the module to configure mode and fix the error. The green status LED of the backup MFP module blinks to indicate it is in the error or configure mode. The first byte of the module status also indicates the mode. Backup MFP module LED 7 blinks and bit 3 of the module status is set to indicate that configuration differences exist between the primary and backup.
n 01xx0x0x ● ●	n+1 00xx1x0x ✱ ○	4. The backup MFP module can now be placed in execute mode provided no errors remain in the new configuration. Make additional configuration changes by entering configure mode (Step 2). If no changes have been made, a backup MFP reset returns the backup module to the state of Step 1. If changes have been made, the backup module must be put into configure mode and initialized to get to the state of Step 1. NOTE: The transition from backup cycle step 4 to 5 occurs automatically after a successful Step 4 backup MFP module execute. The transaction completion time is MFP configuration dependent.

Table B-2. Backup Cycle (continued)

Primary	Backup	Procedure
n 01xx0x0x ● ●	n+1 10xx1x0x ○ ☆	5. When the checkpoint data for the old configuration is received from the primary MFP module, the reconfigured backup MFP module can assume the role of the primary MFP module if a failure is detected in the old configuration (see Step 9). However, the primary MFP module still indicates that no backup is available when the configuration is different. Additional configuration changes can be made by once again entering configure mode (Step 2). If no changes have been made, a backup MFP module reset returns the backup module to the state of Step 1. If changes have been made, the backup module must be put into configure mode and initialized to get to the state of Step 1.
n 01xx0x0x ● ●	n+1 00xx1x0x ○ ○	6. After the changes have been made, switch process control to the reconfigured backup MFP module by pressing and releasing the backup MFP module stop/release button two times. The first time stops the module and the second time resets the module. The backup MFP module comes up in execute mode with the configuration marked as valid.
n 01xx0x0x ● ●	n+1 10xx1x0x ☆ ○	7. Note that backup cycle step transitions from 6 to 7 to 8 to 9 occur automatically after the Step 6 backup MFP module reset. The time it takes to complete these transitions is MFP module configuration dependent. The status indicated in Steps 6, 7, and 8 might not be seen depending on the actual step transition times. The important status to wait for is indicated by Step 9. After the checkpoint data is updated, the backup MFP module is ready to take over the duties of the primary MFP module.
n 01xx0x0x ● ●	n+1 11xx1x0x ○ ☆	8. The backup MFP module requests the primary MFP module to shut down and assume the role of a hot backup (n+1). The backup MFP module waits to act as the primary MFP module (n). (A hot backup is a backup which retains the old configuration and control data and is ready to assume control if an error is detected in the new configuration.)
n+1 01xx0x0x ○ ●	n 01xx1x0x ☆ ☆	9. The primary MFP module has removed the bus clock (BUSCLK) and acts as a hot backup (n+1). The reconfigured backup MFP module is now serving as the primary MFP module (n). Before proceeding to the following commands, insure that LED and module status are as shown in this step. To return to Step 5, reset the backup MFP module (n). This allows correcting a bad configuration. The primary MFP module (n+1) must be reset at this point in order for the on-line configuration cycle to complete. Resetting the primary MFP module (n+1), currently acting as the hot backup, tells it to get a copy of the new configuration.
n+1 10xx0x0x ○ ●	n 00xx0x0x ● ●	10. After the backup MFP module copies the new configuration into the primary MFP module, the cycle is complete. The backup MFP module is now serving as the primary MFP module (n) while the primary handles the backup role (n+1). (Note that the LED combination and module status is the opposite of Step 1 indicating the role reversal.)

Primary Cycle

Refer to Table B-3 for the primary cycle procedure. The step numbers in this cycle correspond to the states of Figure B-2.

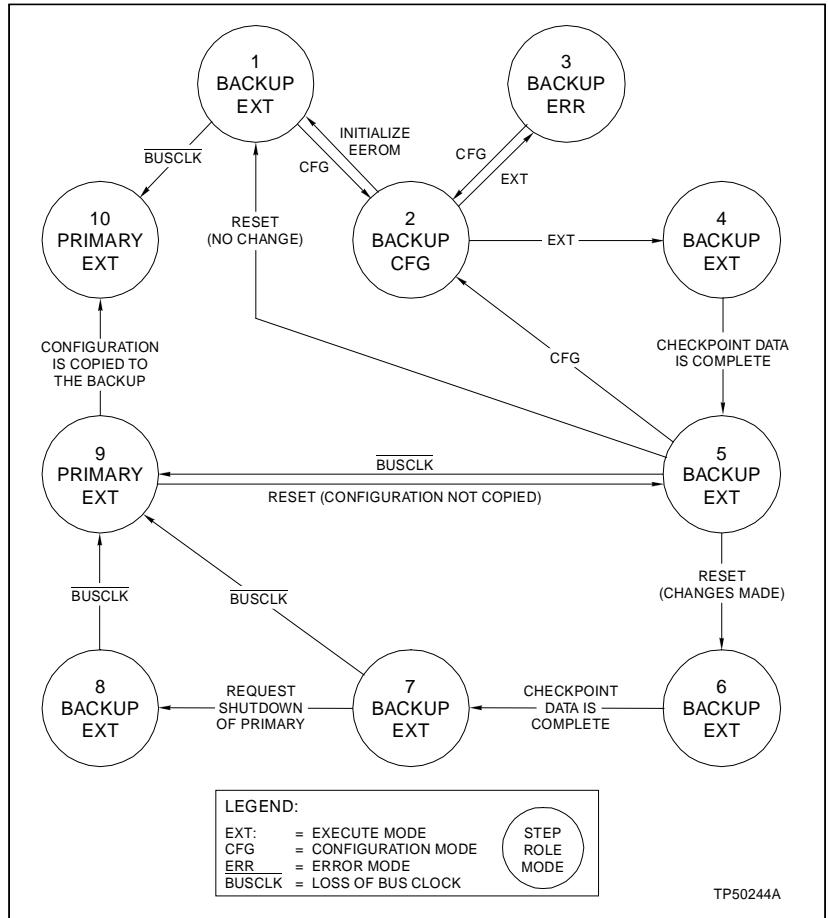

Figure B-1. Backup MFP Module Operating Cycle

This information is provided for status purposes. Follow the backup cycle procedures to perform on-line configuration.

Table B-3. Primary Cycle

Primary	Backup	Procedure
n 01xx0x0x ● ●	n+1 10xx1x0x ○ ✱	1. The primary MFP module is actively controlling the process. (This represents the same juncture as Step 5 of the backup cycle.)
n+1 01xx0x0x ○ ●	n 11xx1x0x ✱ ✱	2. When the shutdown request is received from the backup MFP module (Step 8 of the backup cycle), the primary MFP module stops executing and removes the bus clock (BUSCLK).
n+1 01xx0x0x ○ ●	n 01xx1x0x ✱ ✱	3. The primary MFP module is now acting as the hot backup (n+1). All old configuration and block output information remains intact from when it is shut down in Step 2. If the new configuration is not operating as expected, the primary MFP module, currently acting as the hot backup (n+1), can take control using the old configuration and block output information (returns to Step 1).

Table B-3. Primary Cycle (continued)

Primary	Backup	Procedure
n+1 00xx0x0x ○ ○	n 00xx1x0x ✱ ✱	4. Resetting the primary MFP module (n+1), currently acting as the hot backup, directs it to get a copy of the new configuration (Step 9 of the backup cycle).
n+1 10xx0x0x ● ○	n 00xx0x0x ● ●	5. When the new configuration has been copied, the backup MFP module has completed its cycle, and is now serving as the primary MFP module.
n+1 10xx0x0x ○ ●	n 00xx0x0x ● ●	6. After the checkpoint data is complete, the primary MFP module is now serving as the backup MFP module and is ready to take over the control process with the updated configuration. The primary cycle is complete. (This represents the same juncture as Step 10 of the backup cycle.)

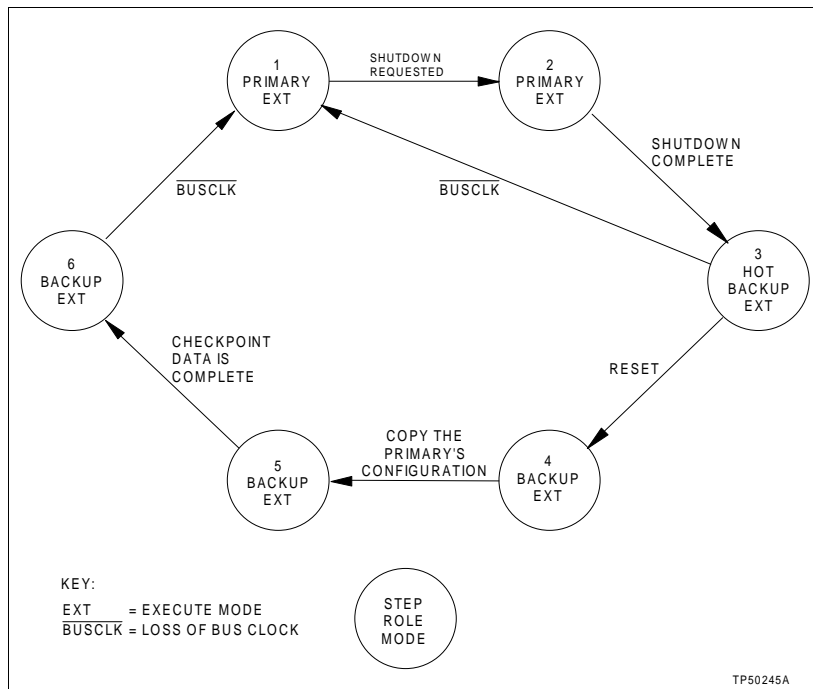

Figure B-2. Primary MFP Module Operating Cycle

APPENDIX C - NTMP01 TERMINATION UNIT CONFIGURATION

INTRODUCTION

The IMMFP01 Multi-Function Processor Module can use the NTMP01 termination unit for termination. Jumpers on the NTMP01 unit configure the two RS-232-C ports for data terminal equipment (DTE) or data communication equipment (DCE). One of the RS-232-C ports can be configured as an RS-485 port. Refer to the NTMP01 product instruction for complete information on applications.

Figures C-1 through C-4 show the jumper configurations for jumpers J1 and J2. Figure C-5 shows the jumper configurations for jumpers J3 through J10. Figure C-6 shows the jumper configurations for jumpers J14 through J17. Figure C-7 shows the NTMP01 connector assignments and jumper locations. Figure C-8 shows the cable connections for redundant MFP modules. Figure C-9 shows the cable connections for a single MFP module.

Jumpers J11 and J12 are storage posts for extra jumpers. Jumper J13 is normally set with pins one and two connected. This connects the cable shielding pin of connector P7 to chassis ground. Jumper J18 configures the terminal serial port for RS-485 operation when pins two and three are connected and connector P7 is used instead of connector P5.

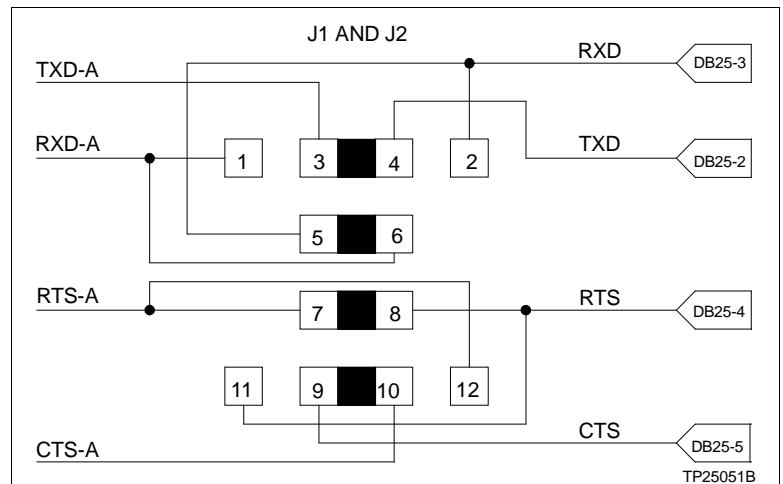

Figure C-1. DTE Jumper Configuration for NTMP01 Termination Unit

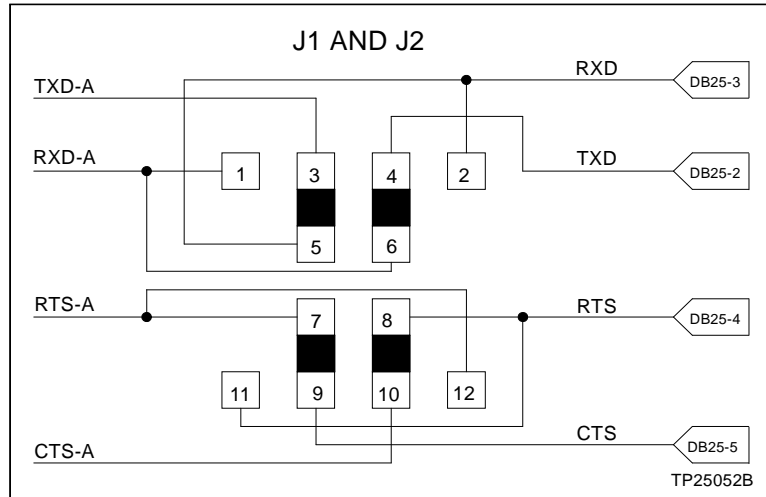

Figure C-2. DCE Jumper Configuration for NTMP01 Termination Unit

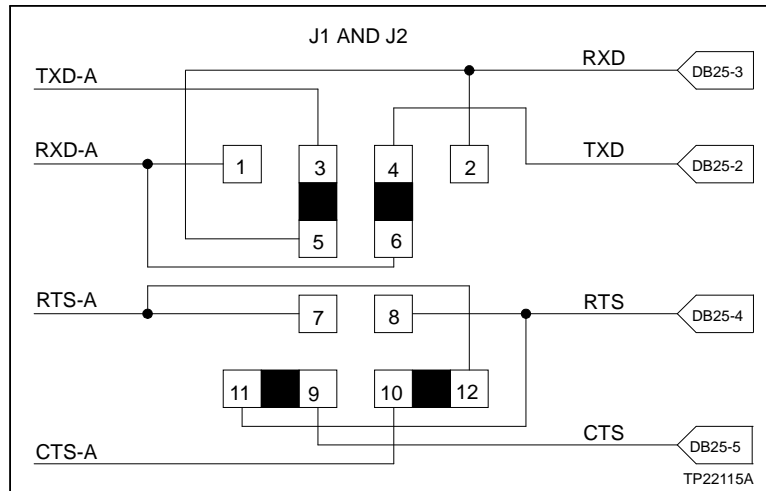

Figure C-3. NTMP01 Nonhandshake Jumper Configuration

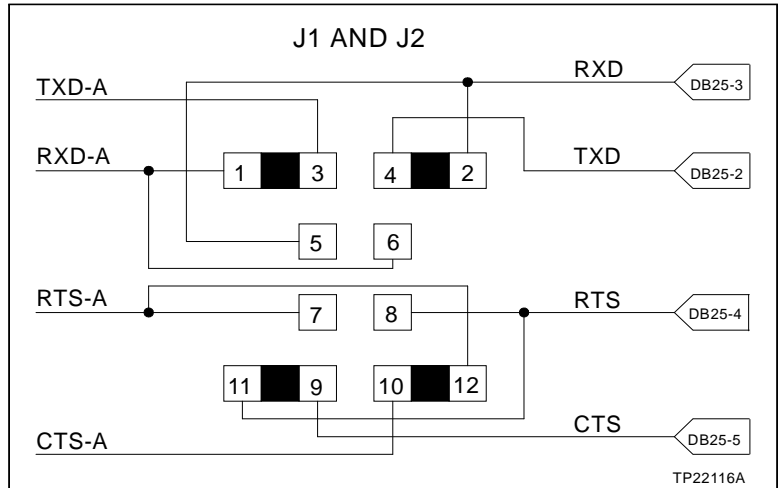

Figure C-4. NTMP01 Loopback Jumper Configuration

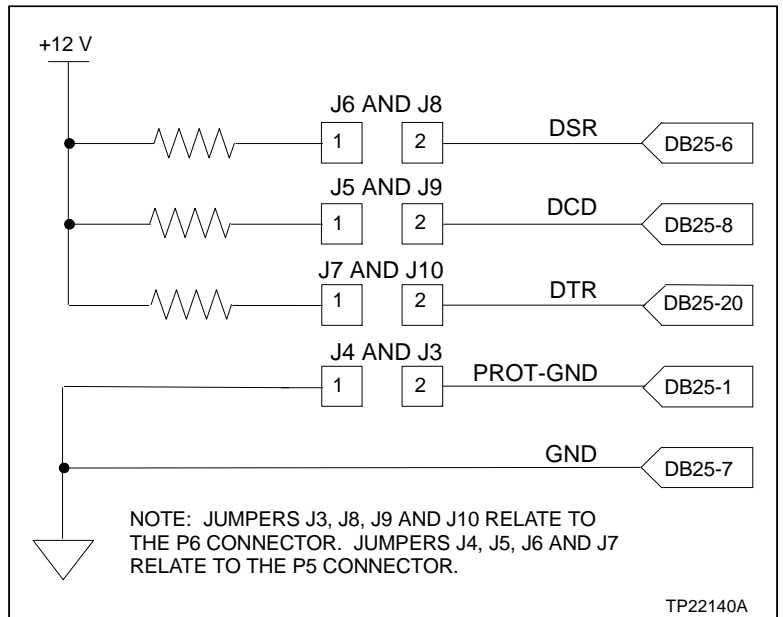

Figure C-5. NTMP01 Jumpers J3 through J10 Configuration

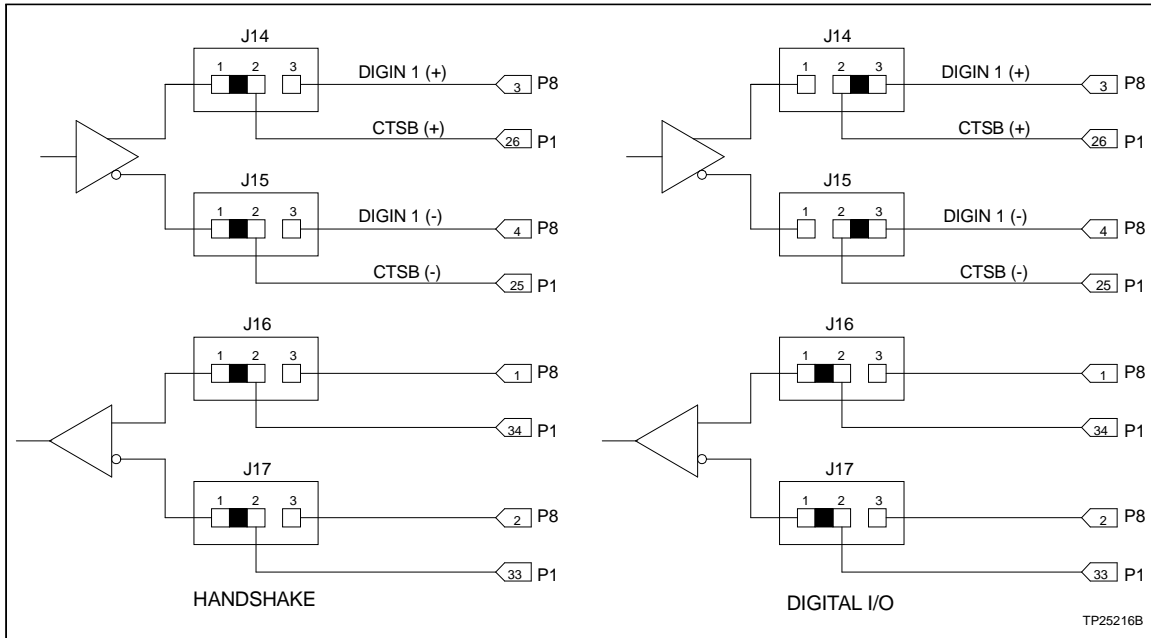

Figure C-6. NTMP01 Jumpers J14 through J17 Configuration

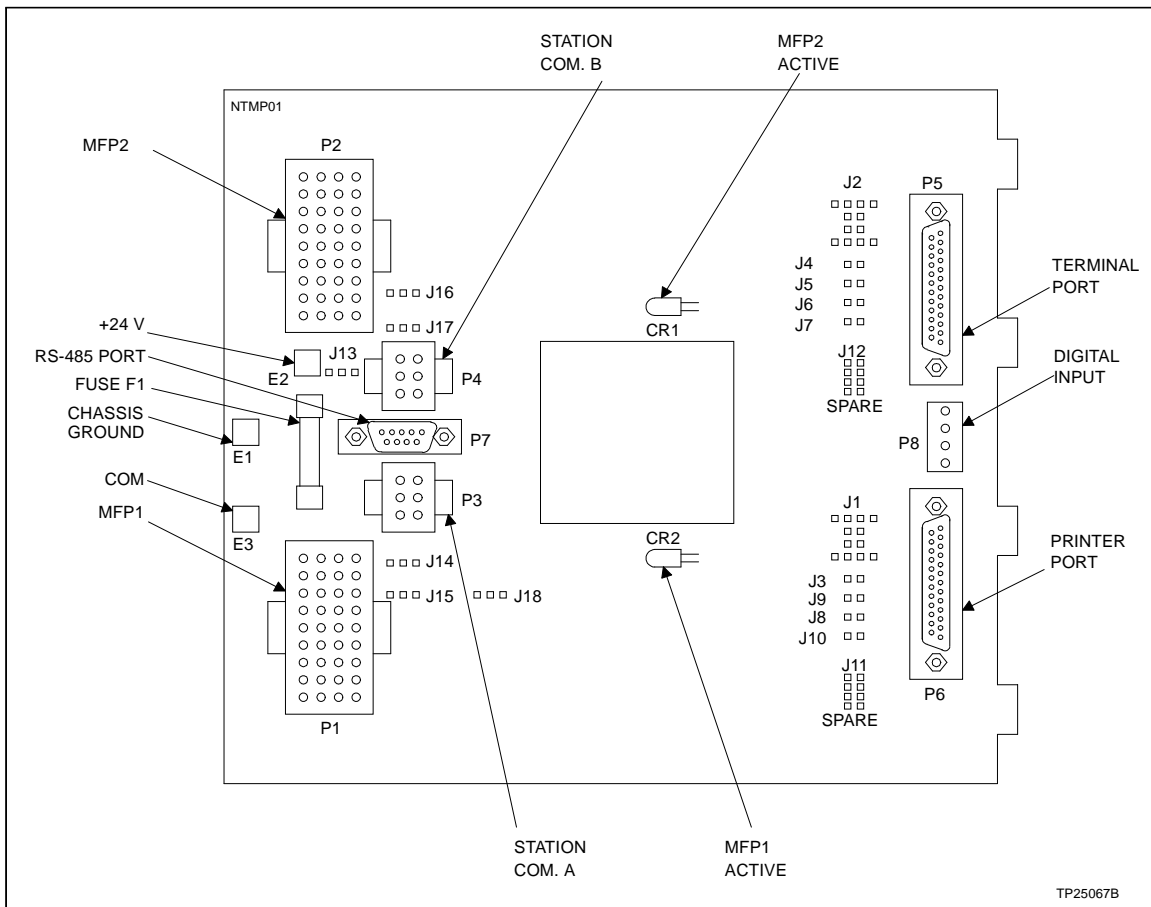

Figure C-7. NTMP01 Connector Assignments and Jumper Locations

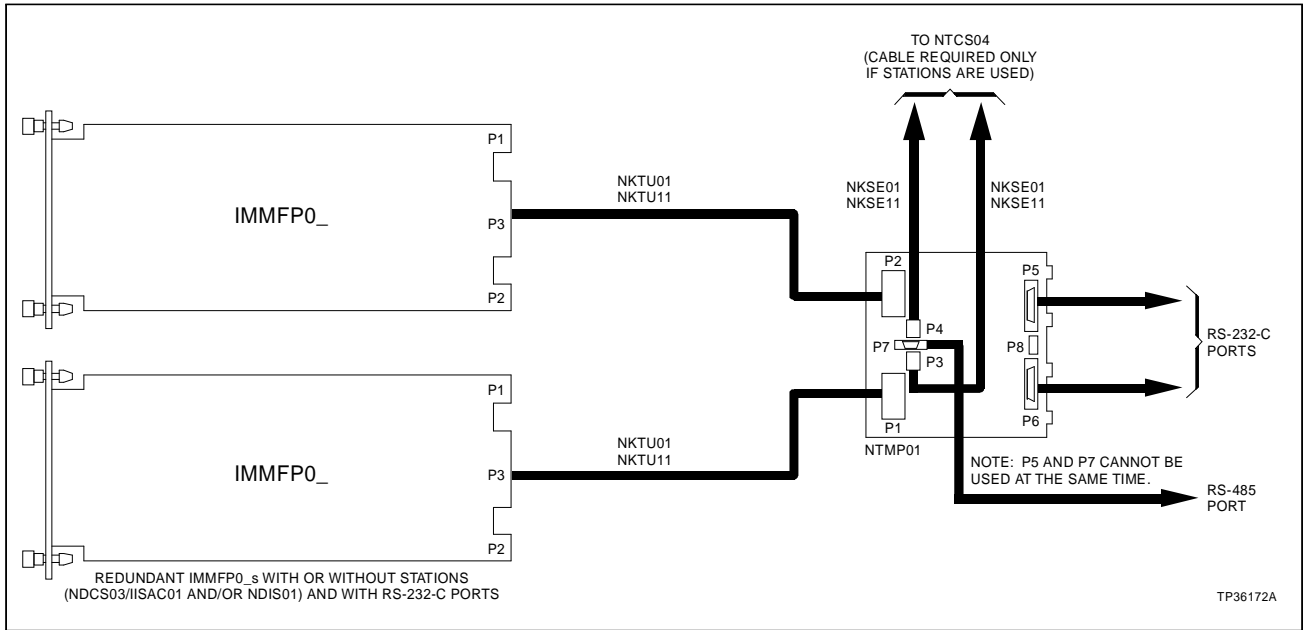

Figure C-8. NTMP01 Cable Connections for Redundant MFP Modules

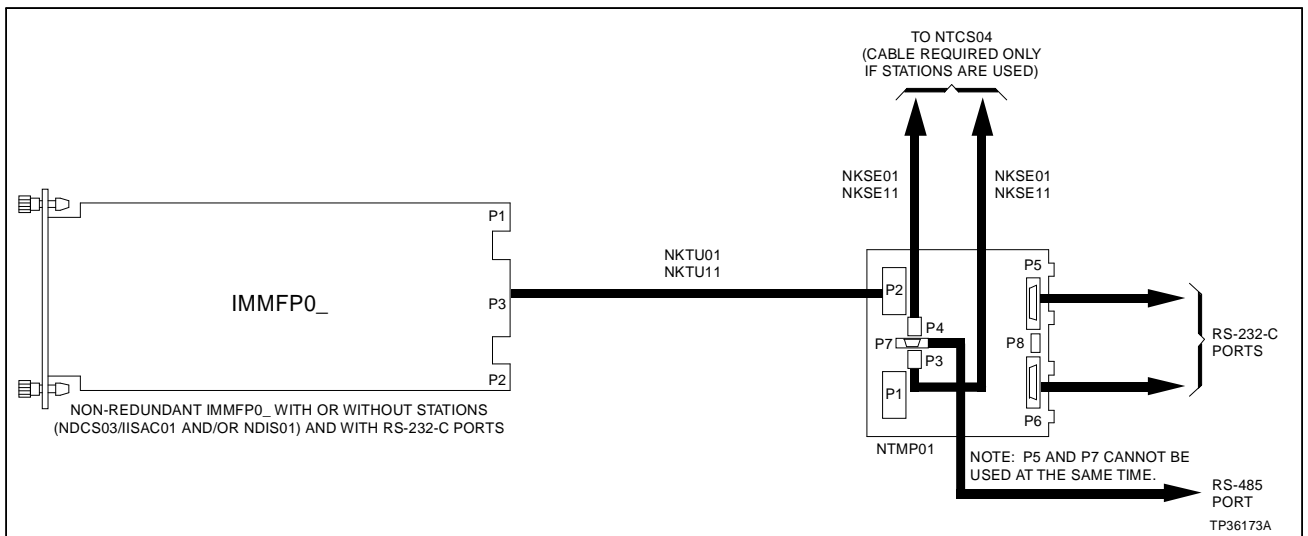

Figure C-9. NTMP01 Cable Connections for a Single MFP Module

APPENDIX D - NIMP01 AND NIMP02 TERMINATION MODULE CONFIGURATION

INTRODUCTION

The IMMFP01 Multi-Function Processor Module can use the NIMP01 or NIMP02 termination module for termination. Jumpers on the NIMP01 module configure the two RS-232-C ports for data terminal equipment (DTE) or data communication equipment (DCE). One of the RS-232-C ports can be configured as an RS-485 port. The NIMP02 module is required when installing redundant MFP modules. Refer to the NIMP01 and NIMP02 product instruction for complete information on termination module applications.

Figures D-1 through D-4 show the jumper configurations for jumpers J1 and J2. Figure D-5 shows the jumper configurations for jumpers J5 through J10. Figure D-6 shows the jumper configurations for jumpers J14 through J17. Figure D-7 shows the NIMP01 connector and jumper locations. Figure D-8 shows the cable connections for redundant MFP modules. Figure D-9 shows the cable connections for a single MFP module.

Jumpers J11 and J12 are storage posts for extra jumpers. Jumper J13 is normally set with pins one and two connected. This connects the cable shielding pin of connector P7 to chassis ground. Jumper J18 configures the terminal serial port for RS-485 operation when pins two and three are connected and connector P7 is used instead of connector P5.

NOTES:

1. RS-232-C port connections on the termination module are through DB-9 connectors. Use Bailey Controls NKMR02 cable to connect a standard piece of equipment (computer or printer with a DB-25 connector) to the IMP module.
2. There are no jumper settings on the NIMP02 termination module. See Figure D-8 for cable connections.

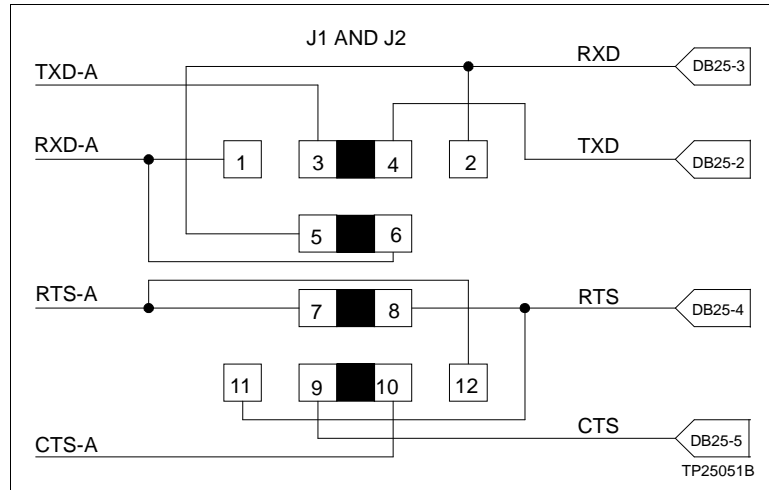

Figure D-1. DTE Jumper Configuration for NIMP01 Termination Module

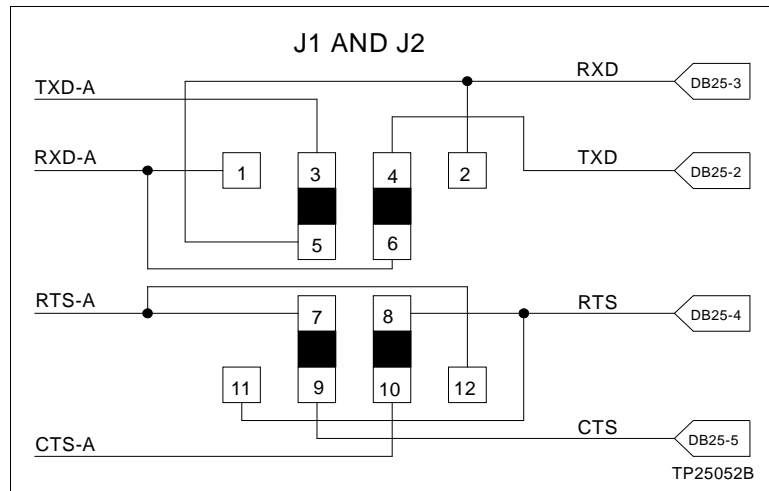

Figure D-2. DCE Jumper Configuration for NIMP01 Termination Module

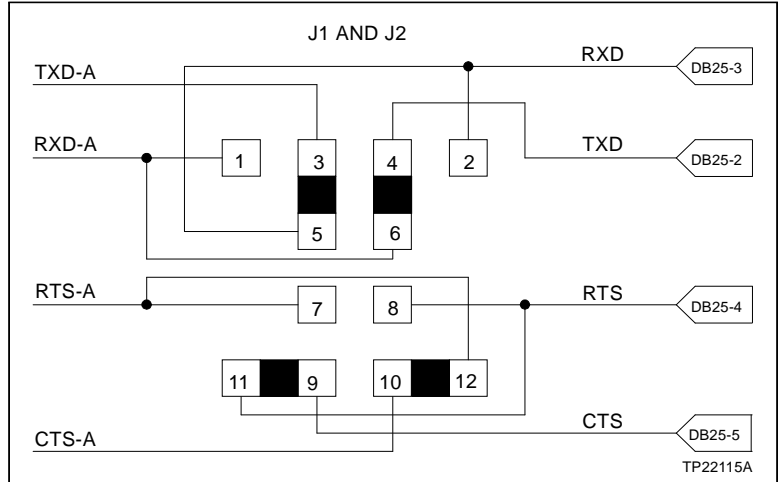

Figure D-3. NIMP01 Nonhandshake Jumper Configuration

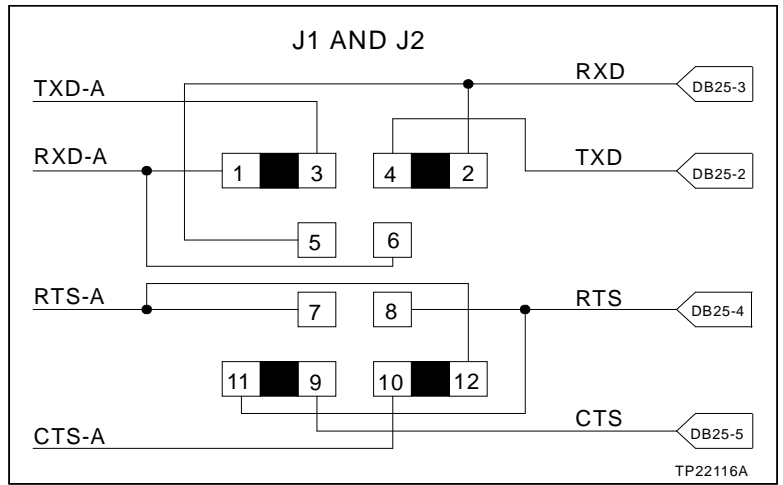

Figure D-4. NIMP01 Loopback Jumper Configuration

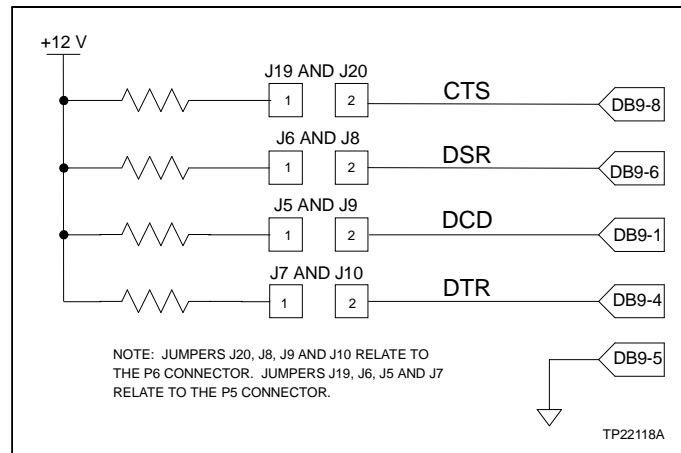

Figure D-5. NIMP01 Jumpers J5 through J10 Configuration

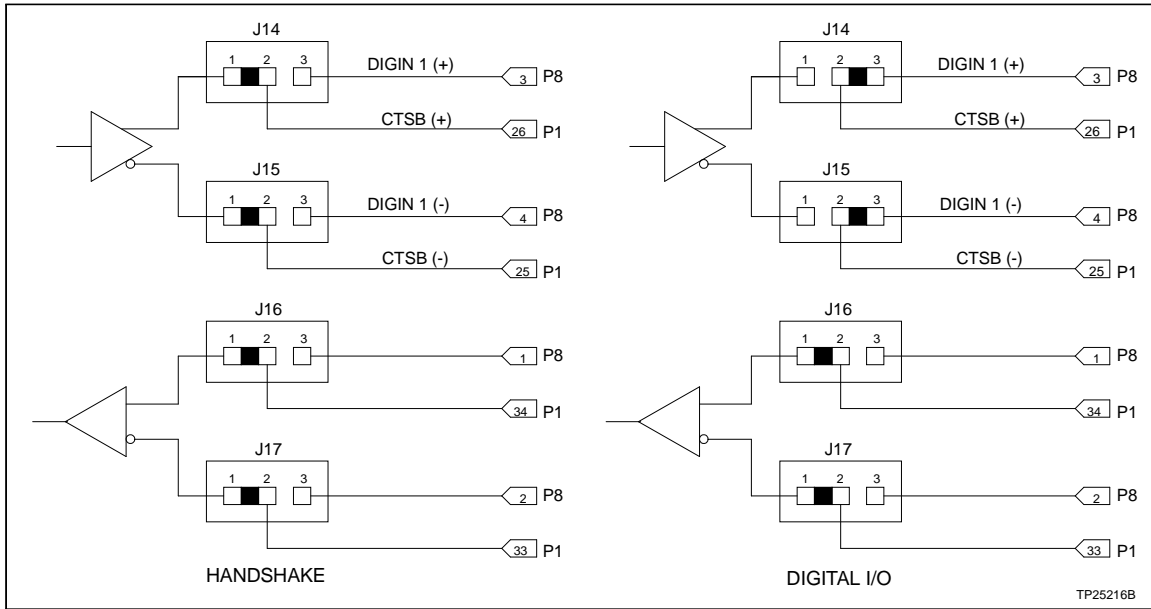

Figure D-6. NIMP01 Jumpers J14 through J17 Configuration

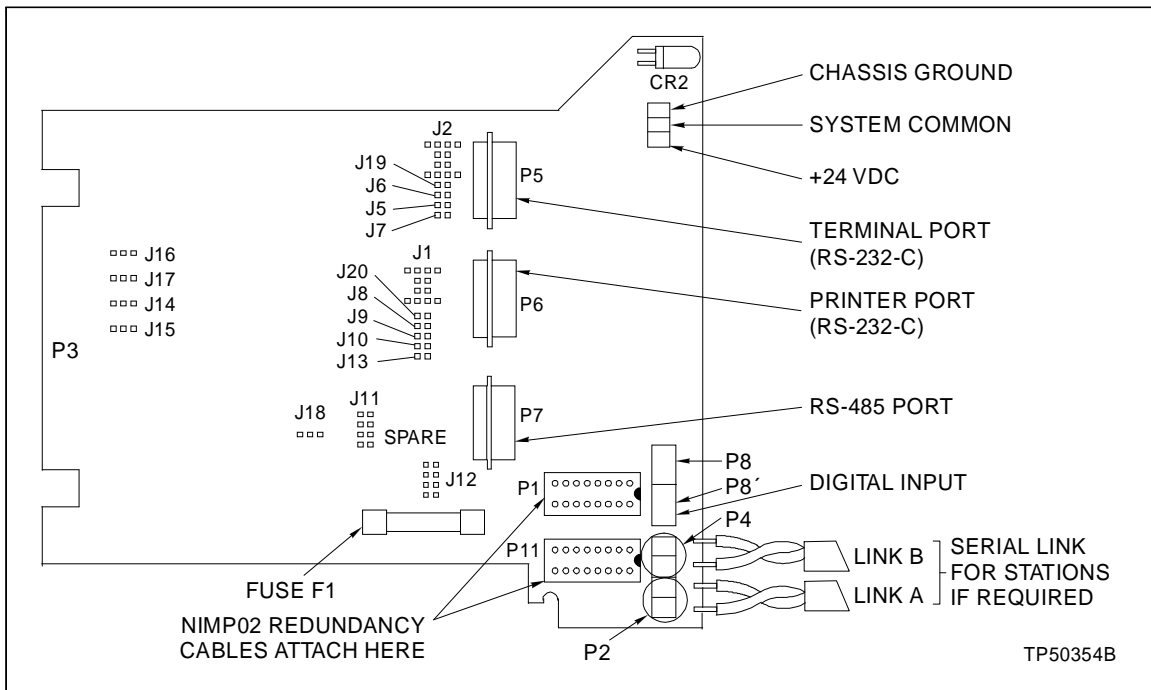

Figure D-7. NIMP01 Connector Assignments and Jumper Locations

NIMP01 AND NIMP02 TERMINATION MODULE CONFIGURATION

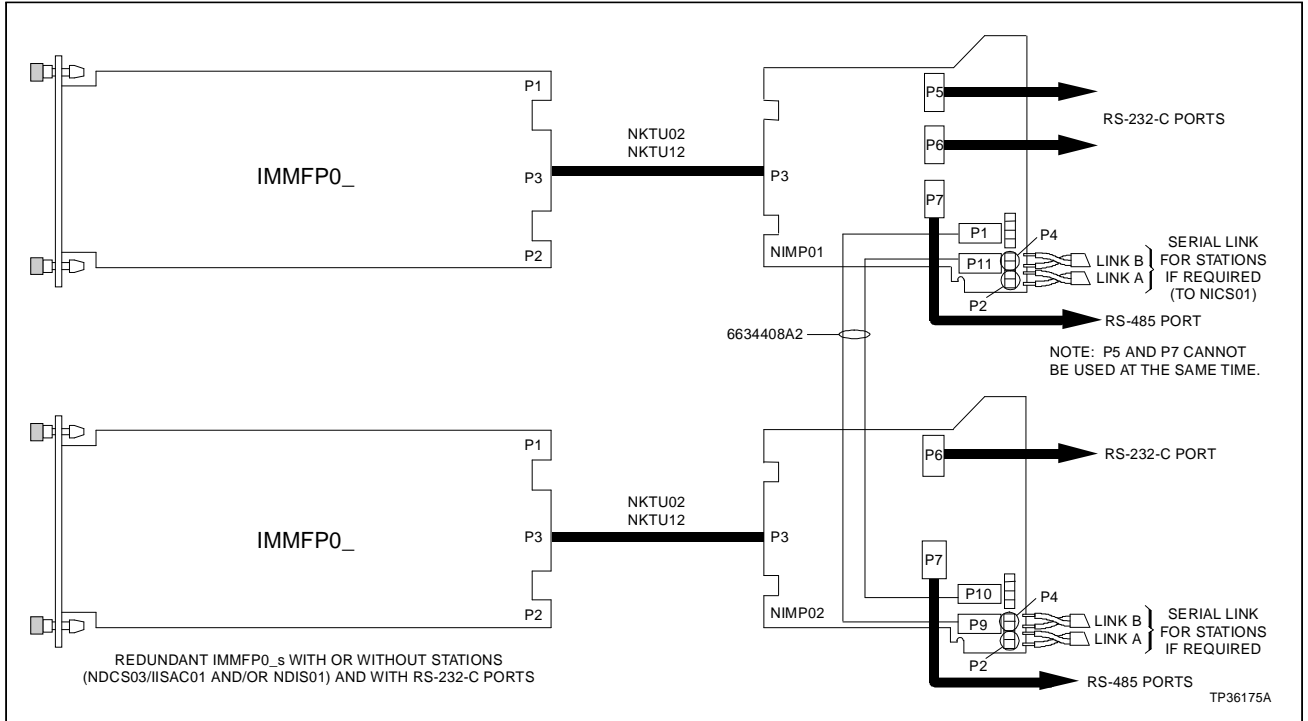

Figure D-8. NIMP01 and NIMP02 Cable Connections for Redundant MFP Modules

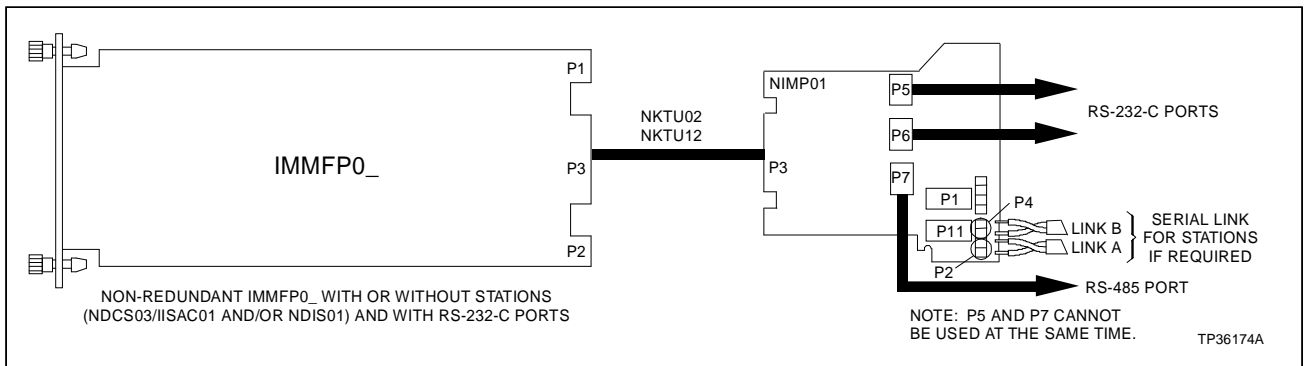

Figure D-9. NIMP01 Cable Connections for a Single MFP Module